

MATERIAL HANDLING CATALOG



Shelving • Cabinets • Workbenches • Lockers



**We Stock It • You Sell It • We Ship It Fast
It Really Is That Easy!**

Hallowell-List.com

Since 1903, every Hallowell component has been designed and manufactured with the concept that the highest quality product is crucial for success.

OUR HISTORY

Hallowell was acquired by List Industries Inc. in 1992. List Industries was founded in 1936 with the idea that customer satisfaction and product quality would be the basis for success. This philosophy has been maintained for 75 years by the three presidents of List Industries Inc.: founder Max H. List, his son Herb List and his grandson and current president, Herb List, Jr. As an innovator and industry leader in product design and development, List Industries Inc. has and will continue to uphold Hallowell's tradition of quality and exceptional customer service.

MANUFACTURING

Hallowell Products are fabricated in three state-of-the-art manufacturing facilities located in Central and South Florida. Our Deerfield Beach corporate headquarters is a highly efficient manufacturing plant located in one of South Florida's premier office parks. Computer controlled fabrication and roll-forming equipment and the newest powder coating paint technology assure consistent quality workmanship. In addition to our primary manufacturing facility, we also have a second plant in a prestigious industrial park in Central Florida that more than doubles our manufacturing square footage. Our third Florida location, and newest addition, produces our new line of all-wood Recruiter sport lockers and wardrobe Club Lockers.

MADE-TO-ORDER PRODUCTS

In addition to Hallowell's industry leading variety of in-stock lockers, shelving and cabinets we also offer an extensive line of production items. Hallowell's complete line of production lockers can be manufactured in short lead-times and painted in one of our 24 standard designer powder coat colors. If a high-rise shelving system is what you require, our team of design engineers and sales professionals is eager to assist you.

TABLE OF CONTENTS

- 2** Company Spotlight
- 3** The Hallowell Difference
- 4** Quick Ship Program & Distribution Center Locations
- 5** Greenguard Certification
- 6** Rivetwell Boltless Steel Shelving
- 18** Hi-Tech Metal Shelving
- 28** H-Post High Capacity Shelving
- 34** DuraTech Pass-Thru Shelving
- 38** Safety Products
- 40** 800 Series Steel Cabinets
- 41** High Visibility Cabinet
- 42** DuraTough All-Welded Cabinets
- 45** Work Benches
- 46** Fort Knox Modular Workbench Storage System
- 50** Premium Wardrobe Lockers
- 52** Premium Box Lockers
- 54** MedSafe Lockers
- 55** ValueMax Lockers
- 56** Safety-View & Safety-View Plus Lockers
- 58** Stainless Steel Lockers
- 59** MaxView Lockers
- 60** Locker Accessories
- 62** Utility Cart
- 63** Benches, Pedestals & Locks





The Industry's Largest Inventory

- Six fully-stocked national distribution centers.
- Over 3,000 different skus to choose from in stock.
- The largest stock product variety.

Two Manufacturing Plants

- Hallowell is proud to be an American manufacturer
- Two state-of-the-art facilities in Florida
- Creating jobs since 1903



Environmentally Responsible

- All Hallowell steel products are GREENGUARD Children & Schools CertifiedSM
- All sheet steel contains 72% recycled content
- All cardboard packaging is of recycled material



All KD Cabinets And Lockers Are Available Fully-Assembled

- Lockers and cabinets are factory assembled by trained and highly skilled trade professionals.
- Lockers and cabinets arrive ready to setup and anchor, saving you time and money.

Powder Coat Finish

- All Hallowell products are finished with a durable powder coat finish
- Most environmentally friendly method of paint finishing.



Industry-Leading Customer Service

- A dedicated team of in-house trained professionals is ready to respond to inquiries related to product features, availability, specifications, order status and shipping information.
- All personnel are trained in every aspect of our Quick Ship program.

STOCK  PROGRAM**Quick Ship****INDUSTRY'S LARGEST
QUICK-SHIP PROGRAM****THE FASTEST SHIPPING IN THE INDUSTRY...****Our National QUICK-SHIP Program is the largest of it's kind in the material handling industry.**

Our six distribution centers are strategically located to allow for localized distribution. All Hallowell distribution centers are company owned and operated to insure your orders are properly prioritized and that all operations are per our company philosophy.

Our unparalleled array of products and services assures that your order will ship fast and secure while saving you time and money on shipping costs. Logistics, service and product offering is what positions Hallowell at the forefront of the industry.

- ✓ **QUICK-SHIP Shelving** is available in a variety of sizes, styles and color options. with shelf capacities up to 1,250 pounds, you can be sure our shelving will outperform all competitors. Choose from traditional, rivet type or our unique pass thru models which allow true four-sided access. Hallowell stocks a shelving system to meet your specific storage requirements.
- ✓ **QUICK-SHIP Cabinets** Cabinets are engineered above industry standards. With multiple colors, styles, sizes and accessories, we are confident we can be your one-stop cabinet supplier. Specialty cabinets offering corrosion resistance, antimicrobial properties or textured finish help you to offer your customer products targeted specifically to their needs.
- ✓ **QUICK-SHIP Workbenches** Workbenches Our new Ft. Knox Modular utility Storage System combines shelving, cabinets, workbenches and lockers to create a functional, durable and customizable work center. Our unique textured two-tone powder coat process provides an attractive durable protective finish.
- ✓ **QUICK-SHIP Lockers** Lockers are available in 25 different styles comprised of more than 1,200 SKUs which allows you the benefit of selecting a locker to meet your specific storage needs. A complete line of locker accessories is available from stock to help you complete your locker system. Order your lockers to ship fully-assembled to take full advantage of our expertise. Your lockers will be packaged above industry standards to insure a safe arrival.

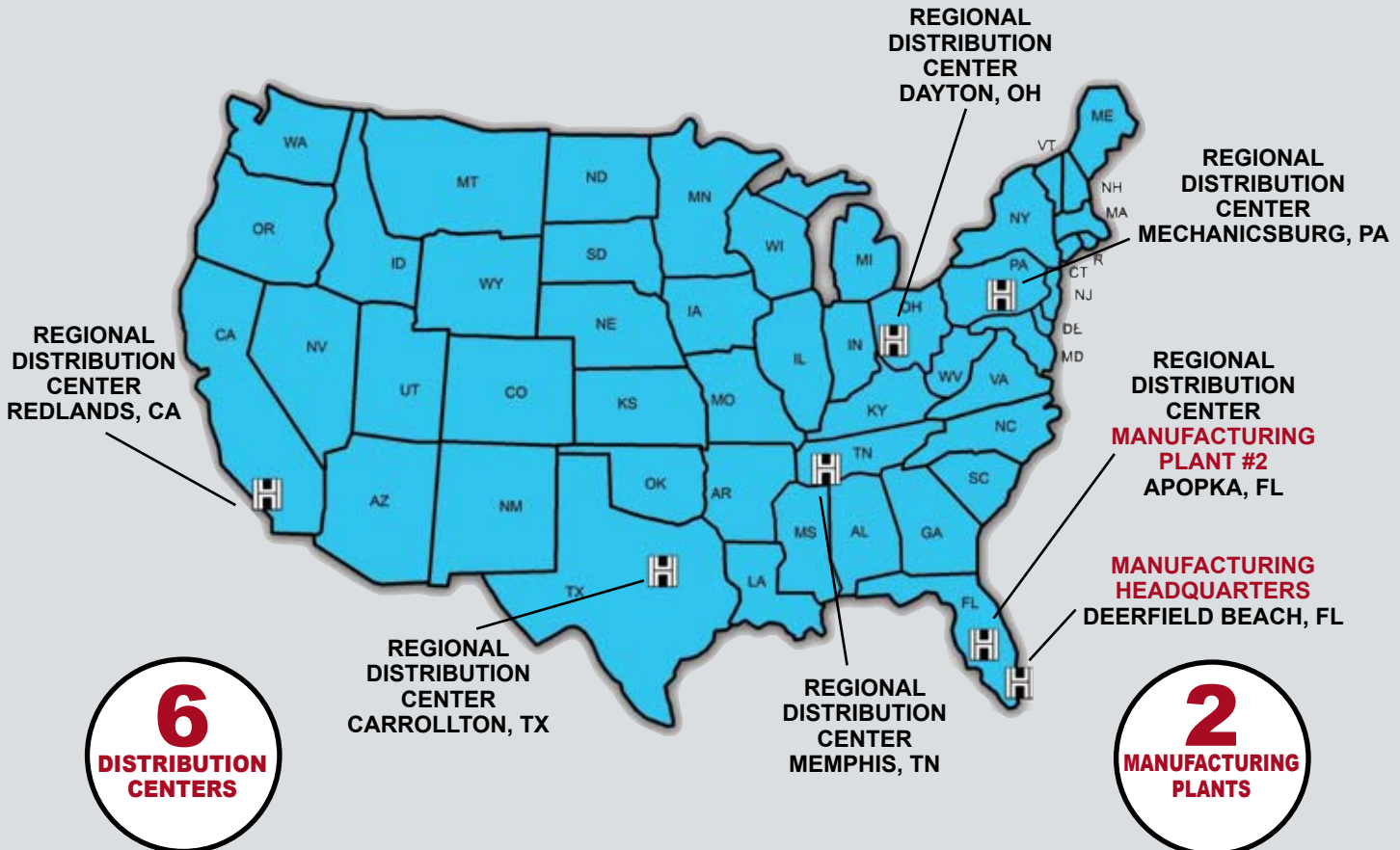
**All Products
In-Stock**

Hallowell® is committed to minimizing the environmental impact of our products and protecting indoor air quality

- **GREENGUARD** is an indoor air quality certification program for low emitting products and materials that evaluates over 75,000 chemicals, including volatile organic compounds, carcinogens and reproductive toxins.
- **GREENGUARD** certification is referenced in both the Collaborative for High Performance Schools (CHPS) and the Leadership for Energy and Environmental Design (LEED) Building Rating System.
- **GREENGUARD** Children & Schools Certification establishes strict chemical emission standards for products intended for use in environments where children and others work, play or reside.

GREENGUARD Emission Criteria Children & Schools Program

Individual VOCs	≤ 1/100 TLV and ≤ CA chronic REL
Formaldehyde	≤ 0.0135 ppm/13.5 ppb
Total VOCs	≤ 0.22 mg/m ³
Total Aldehydes	≤ 0.043 ppm/43 ppb
Total Phthalates	≤ 0.01 mg/m ³
Total Particles(≤ 10µm)	≤ 0.02 mg/m ³



STOCK → PROGRAM

Quick Ship

BOLTLESS SHELVING UNITS

THE FASTEST SHIPPING IN THE INDUSTRY...

RIVETWELL™ SHELVING

RIVETWELL™

Boltless shelving is designed to maximize storage space and minimize installation set-up time.

All components are engineered to attach snugly to one another without the use of loose fasteners. This unique design has rivets which are factory attached to all left-to-right and front-to-back beams. The rivets align with keyhole slots in the vertical posts. Once tapped into place using a standard rubber mallet, the units are tightly assembled providing maximum strength.

Standard units consist of vertical angle posts at the corners, double rivet angle beams at the top and bottom perimeter and single rivet angle beams running left-to-right only at the intermediate levels. Shelves are of standard 5/8" particle board, EZ-Deck steel or wire decking and simply drop into place. Shelf strength can be increased by upgrading to heavy duty beams, adding single rivet beams running front-to-back at the intermediate levels, upgrading to double rivet beams at the full perimeter of the intermediate levels or upgrading all levels to our strongest double rivet channel beams. Optional center supports can be added using supplied hardware to increase decking capacity.



Double Rivet unit with 5 levels



Single Rivet unit with 4 levels

Double Rivet unit with 4 levels

The versatility of our Rivetwell boltless shelving system allows you to mix and match components to meet your unique application. From standard storage applications, record storage to automotive tire racks, Rivetwell boltless shelving is your storage solution.



COLOR SELECTION
729 PARCHMENT (PT)

BOLTLESS SHELVING COMPONENTS

Hallowell

www.Hallowell-List.com

RIVETWELL™ SHELVING

1 Angle Post



2 T-Post



1 Angle Post (Standard Duty): 1-1/2" x 1-1/2" x 14 gauge cold rolled steel corner post uprights. Perfect for standard load situations.

Angle Post (Heavy Duty): Shall be 1-7/8" x 1-7/8" x 14 gauge cold rolled steel uprights. The choice when heavy duty shelving is required. Perfect for multilevel installations.

2 T-Post (Standard Duty): 3" x 1-7/8" x 14 gauge cold rolled steel intermediate uprights.

T-Post (Heavy Duty): 3-3/4" x 1-7/8" x 14 gauge cold rolled steel intermediate uprights.

3 Single Rivet Shelf Beam (Standard Duty): This 14 gauge low profile standard intermediate level shelf beam is perfect when maximum clear opening is required between shelf levels.

Single Rivet Shelf Beam (Heavy Duty): An 11 gauge heavy duty version of our low profile intermediate shelf beam allowing maximum clear opening between shelf levels.

4 Double Rivet Angle Beam (Standard Duty): This 16 gauge shelf beam is essential for stability of standard units; therefore, is used on all four sides at the top and bottom levels. Can also be used front and back or on all four sides of intermediate levels to increase unit stability and load capacity.

Double Rivet Angle Beam (Heavy Duty): An upgrade to our standard duty double rivet angle beams, our heavy duty double rivet angle beams provide additional unit rigidity and even higher shelf capacity.

5 Double Rivet Channel Beam: Maximized left-to-right shelf capacity is achieved using our 14 gauge double rivet channel beams in lieu of double rivet angle beams. These beams cannot be used at the bottom level.

6 Center Support: Used to provide additional shelf support front-to-back by bolting between double rivet beams at prepunched locations. Ideal for wider spans.

7 Double Rivet Z-Beam (Standard Duty): For 12" thru 60" beams. Used in place of double rivet angle beams to add 1" additional clearance between shelf levels. Allows particle board decking to sit flush with beam. Protects decking edges. When used at bottom level of single rivet units, shelf clearance is increased by 1" at lower level. Standard Z beams are 14 gauge.

8 Double Rivet Z-Beam (Heavy Duty): For 69" and 72" beams. Used in place of double rivet angle beams to add 1" additional clearance between shelf levels. Allows particle board decking to sit flush with beam. Protects decking edges. Heavy-Duty Z beams are 14 gauge.

9 Center Support for Z-Beam: Used with Z-Beams for front to back decking support. Fabricated of 11 gauge cold rolled steel.

3 Single Rivet Shelf Beam

4 Double Rivet Angle Beam

5 Double Rivet Channel Beam

6 Center Support

7 Double Rivet Z-Beam (Standard Duty)

8 Double Rivet Z-Beam (Heavy Duty)

9 Z-Beam Center Support

5 DAY SHIPPING ON ALL IN-STOCK PRODUCTS

UNIT GROWTH CHART

When designing a shelving layout. Unit growth must be considered. To determine the overall dimension of a continuous row of shelving employing T-Posts or Angle Posts with tie plates, refer to the table below.

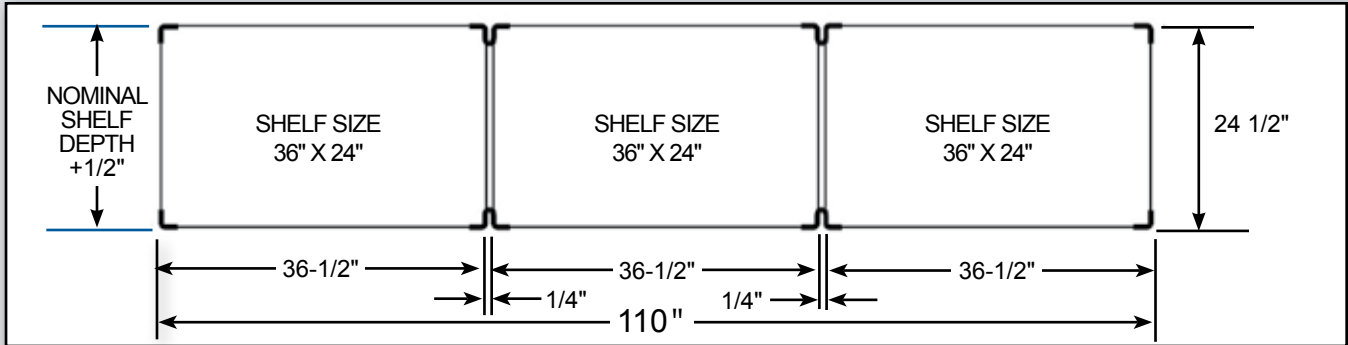

UNIT CLEAR WIDTH Examples below are based on 36" wide shelf.

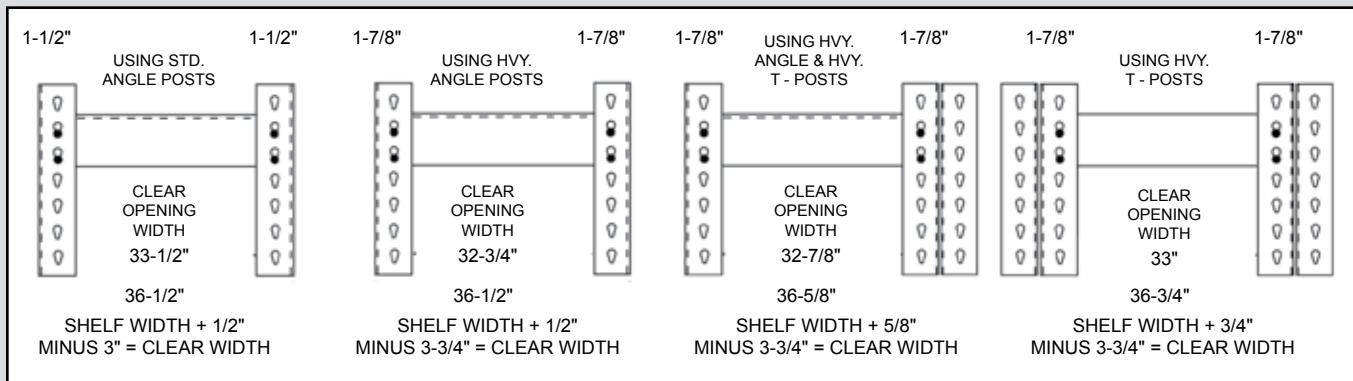

VERTICAL SHELF CLEARANCE FOR SINGLE RIVET UNITS

This chart depicts shelf clearances for typical rivetwell shelving units with 1-1/2" vertical shelf adjustment

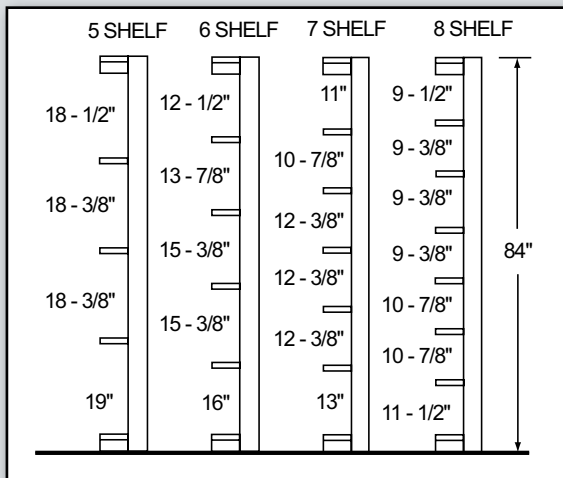

VERTICAL SHELF CLEARANCE FOR DOUBLE RIVET UNITS

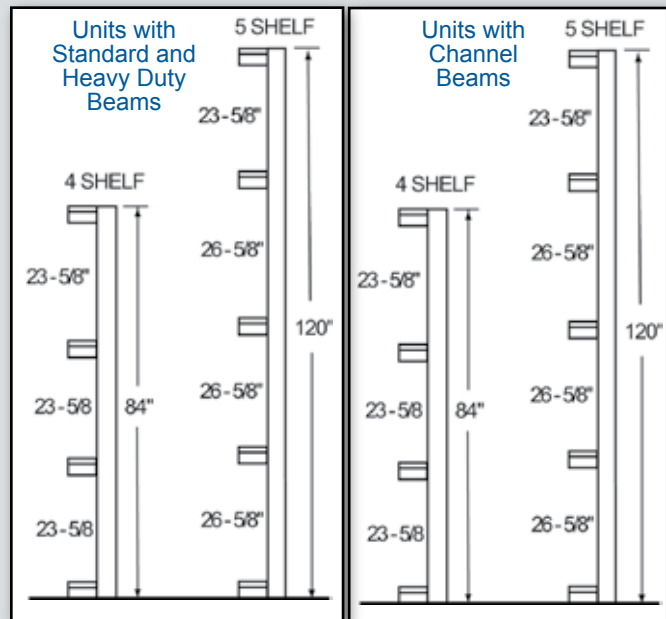

SINGLE RIVET SHELVING UNITS 84" HIGH

Hallowell

www.Hallowell-List.com

RIVETWELL™ SHELVING

SINGLE RIVET UNITS - 84" HIGH							
36" Wide Units				48" Wide Units			
(Decking not included)				(Decking not included)			
Levels	Depth	Shelf Capacity	Starter Model No.	Adder Model No.	Shelf Capacity	Starter Model No.	Adder Model No.
	12	350	SRS361284-5S	SRS361284-5A	250	SRS481284-5S	SRS481284-5A
	18	350	SRS361884-5S	SRS361884-5A	250	SRS481884-5S	SRS481884-5A
	24	350	SRS362484-5S	SRS362484-5A	250	SRS482484-5S	SRS482484-5A
	30	350	SRS363084-5S	SRS363084-5A	250	SRS483084-5S	SRS483084-5A
	36	350	SRS363684-5S	SRS363684-5A	250	SRS483684-5S	SRS483684-5A
6 Shelf Units	12	350	SRS361284-6S	SRS361284-6A	250	SRS481284-6S	SRS481284-6A
	18	350	SRS361884-6S	SRS361884-6A	250	SRS481884-6S	SRS481884-6A
	24	350	SRS362484-6S	SRS362484-6A	250	SRS482484-6S	SRS482484-6A
	30	350	SRS363084-6S	SRS363084-6A	250	SRS483084-6S	SRS483084-6A
	36	350	SRS363684-6S	SRS363684-6A	250	SRS483684-6S	SRS483684-6A
7 Shelf Unit	12	350	SRS361284-7S	SRS361284-7A	250	SRS481284-7S	SRS481284-7A
	18	350	SRS361884-7S	SRS361884-7A	250	SRS481884-7S	SRS481884-7A
	24	350	SRS362484-7S	SRS362484-7A	250	SRS482484-7S	SRS482484-7A
	30	350	SRS363084-7S	SRS363084-7A	250	SRS483084-7S	SRS483084-7A
	36	350	SRS363684-7S	SRS363684-7A	250	SRS483684-7S	SRS483684-7A
8 Shelf Unit	12	350	SRS361284-8S	SRS361284-8A	250	SRS481284-8S	SRS481284-8A
	18	350	SRS361884-8S	SRS361884-8A	250	SRS481884-8S	SRS481884-8A
	24	350	SRS362484-8S	SRS362484-8A	250	SRS482484-8S	SRS482484-8A
	30	350	SRS363084-8S	SRS363084-8A	250	SRS483084-8S	SRS483084-8A
	36	350	SRS363684-8S	SRS363684-8A	250	SRS483684-8S	SRS483684-8A

Starter units consist of four standard angle posts, four left-to-right standard double rivet angle beams, four front-to-back standard double rivet angle beams, two left-to-right standard single rivet beams per intermediate level and two front-to-back standard single rivet beam at one intermediate level only (30" and 36" deep units include two front-to-back standard single rivet beams at each intermediate level).

Adder units consist of two standard T-Posts, four left-to-right standard double rivet angle beams, two front-to-back standard double rivet angle beam, two left-to-right standard single rivet beam per intermediate level and one front-to-back standard single rivet beam at one intermediate level only (30" and 36" deep units include one front-to-back single rivet beam at each intermediate level).

PARTICLE BOARD DECKING	
SIZE	PART NO.
36" X 12"	HPB3612
36" X 18"	HPB3618
36" X 24"	HPB3624
36" X 30"	HPB3630
36" X 36"	HPB3636
48" X 12"	HPB4812
48" X 18"	HPB4818
48" X 24"	HPB4824
48" X 30"	HPB4830

Be sure to order one each of particle board decking per level.

EZ-Deck steel decking can NOT be used on single rivet units.



Standard 5-shelf single rivet unit (order decking separately)

Standard 4-shelf double rivet unit, see page 78. (order decking separately)



5 DAY SHIPPING ON ALL IN-STOCK PRODUCTS

STOCK → **PROGRAM**

Quick Ship

DOUBLE RIVET SHELVING UNITS

THE FASTEST SHIPPING IN THE INDUSTRY...

RIVETWELL™ SHELVING

DOUBLE RIVET UNITS - 84" HIGH WITH 4 LEVELS

Width	Beam Type	Depth	Shelf Cap	Without Center Support (Decking Not Included)		Shelf Cap	With Center Support (Decking Not Included)		Decking	
				Starter Model No.	Adder Model No.		Starter Model No.	Adder Model No.	Particle Board Decking	EZ-Deck Steel Decking
48"	Standard	18	550	DRS481884-4S	DRS481884-4A	875	DRSC481884-4S	DRSC481884-4A	HPB4818	HEZD4818
		24	550	DRS482484-4S	DRS482484-4A	875	DRSC482484-4S	DRSC482484-4A	HPB4824	HEZD4824
	30	550	DRS483084-4S	DRS483084-4A	825	DRSC483084-4S	DRSC483084-4A	HPB4830	HEZD4830	
	36	550	DRS483684-4S	DRS483684-4A	775	DRSC483684-4S	DRSC483684-4A	HPB4836	HEZD4836	
	48	550	DRS484884-4S	DRS484884-4A	700	DRSC484884-4S	DRSC484884-4A	HPB4848	HEZD4848	
48"	Heavy-Duty	18	750	DRH481884-4S	DRH481884-4A	1400	DRHC481884-4S	DRHC481884-4A	HPB4818	HEZD4818
		24	750	DRH482484-4S	DRH482484-4A	1400	DRHC482484-4S	DRHC482484-4A	HPB4824	HEZD4824
	30	750	DRH483084-4S	DRH483084-4A	1310	DRHC483084-4S	DRHC483084-4A	HPB4830	HEZD4830	
	36	750	DRH483684-4S	DRH483684-4A	1220	DRHC483684-4S	DRHC483684-4A	HPB4836	HEZD4836	
	48	750	DRH484884-4S	DRH484884-4A	1125	DRHC484884-4S	DRHC484884-4A	HPB4848	HEZD4848	
60"	Heavy-Duty	18	600	DRH601884-4S	DRH601884-4A	1200	DRHC601884-4S	DRHC601884-4A	HPB6018	HEZD6018
		24	600	DRH602484-4S	DRH602484-4A	1200	DRHC602484-4S	DRHC602484-4A	HPB6024	HEZD6024
	30	600	DRH603084-4S	DRH603084-4A	1200	DRHC603084-4S	DRHC603084-4A	HPB6030	HEZD6030	
	36	600	DRH603684-4S	DRH603684-4A	1200	DRHC603684-4S	DRHC603684-4A	HPB6036	HEZD6036	
	48	600	DRH604884-4S	DRH604884-4A	1200	DRHC604884-4S	DRHC604884-4A	HPB6048	HEZD6048	
60"	Channel Beam	18	-	-	-	2000	DRCC601884-4S	DRCC601884-4A	HPB6018	HEZD6018
		24	-	-	-	2000	DRCC602484-4S	DRCC602484-4A	HPB6024	HEZD6024
	30	-	-	-	2000	DRCC603084-4S	DRCC603084-4A	HPB6030	HEZD6030	
	36	-	-	-	2000	DRCC603684-4S	DRCC603684-4A	HPB6036	HEZD6036	
	48	-	-	-	2000	DRCC604884-4S	DRCC604884-4A	HPB6048	HEZD6048	
72"	Heavy-Duty	18	500	DRH721884-4S	DRH721884-4A	1000	DRHC721884-4S	DRHC721884-4A	HPB7218	HEZD7218
		24	500	DRH722484-4S	DRH722484-4A	1000	DRHC722484-4S	DRHC722484-4A	HPB7224	HEZD7224
	30	500	DRH723084-4S	DRH723084-4A	1000	DRHC723084-4S	DRHC723084-4A	HPB7230	HEZD7230	
	36	500	DRH723684-4S	DRH723684-4A	1000	DRHC723684-4S	DRHC723684-4A	HPB7236	HEZD7236	
	48	500	DRH724884-4S	DRH724884-4A	1000	DRHC724884-4S	DRHC724884-4A	HPB7248	HEZD7248	
72"	Channel Beam	18	-	-	-	1850	DRCC721884-4S	DRCC721884-4A	HPB7218	HEZD7218
		24	-	-	-	1850	DRCC722484-4S	DRCC722484-4A	HPB7224	HEZD7224
	30	-	-	-	1850	DRCC723084-4S	DRCC723084-4A	HPB7230	HEZD7230	
	36	-	-	-	1850	DRCC723684-4S	DRCC723684-4A	HPB7236	HEZD7236	
	48	-	-	-	1850	DRCC724884-4S	DRCC724884-4A	HPB7248	HEZD7248	
96"	Heavy-Duty	18	-	-	-	620	DRHC961884-4S	DRHC961884-4A	HPB9618	HEZD9618
		24	-	-	-	620	DRHC962484-4S	DRHC962484-4A	HPB9624	HEZD9624
	30	-	-	-	620	DRHC963084-4S	DRHC963084-4A	HPB9630	HEZD9630	
	36	-	-	-	620	DRHC963684-4S	DRHC963684-4A	HPB9636	HEZD9636	
	48	-	-	-	620	DRHC964884-4S	DRHC964884-4A	HPB9648	HEZD9648	
96"	Channel Beam	18	-	-	-	1400	DRCC961884-4S	DRCC961884-4A	HPB9618	HEZD9618
		24	-	-	-	1400	DRCC962484-4S	DRCC962484-4A	HPB9624	HEZD9624
	30	-	-	-	1400	DRCC963084-4S	DRCC963084-4A	HPB9630	HEZD9630	
	36	-	-	-	1400	DRCC963684-4S	DRCC963684-4A	HPB9636	HEZD9636	
	48	-	-	-	1400	DRCC964884-4S	DRCC964884-4A	HPB9648	HEZD9648	

DOUBLE RIVET UNITS - 120" HIGH WITH 5 LEVELS

72"	Heavy-Duty Angle Beam	30	500	DRH7230120-5S	DRH7230120-5A	1000	DRHC7230120-5S	DRHC7230120-5A	HPB7230	HEZD7230
		36	500	DRH7236120-5S	DRH7236120-5A	1000	DRHC7236120-5S	DRHC7236120-5A	HPB7236	HEZD7236
		48	500	DRH7248120-5S	DRH7248120-5A	1000	DRHC7248120-5S	DRHC7248120-5A	HPB7248	HEZD7248
72"	Channel Beam	30	-	-	-	1490	DRCC7230120-5S	DRCC7230120-5A	HPB7230	HEZD7230
		36	-	-	-	1490	DRCC7236120-5S	DRCC7236120-5A	HPB7236	HEZD7236
		48	-	-	-	1490	DRCC7248120-5S	DRCC7248120-5A	HPB7248	HEZD7248
96"	Heavy-Duty Angle Beam	30	-	-	-	620	DRHC9630120-5S	DRHC9630120-5A	HPB9630	HEZD9630
		36	-	-	-	620	DRHC9636120-5S	DRHC9636120-5A	HPB9636	HEZD9636
		48	-	-	-	620	DRHC9648120-5S	DRHC9648120-5A	HPB9648	HEZD9648
96"	Channel Beam	30	-	-	-	1400	DRCC9630120-5S	DRCC9630120-5A	HPB9630	HEZD9630
		36	-	-	-	1400	DRCC9636120-5S	DRCC9636120-5A	HPB9636	HEZD9636
		48	-	-	-	1400	DRCC9648120-5S	DRCC9648120-5A	HPB9648	HEZD9648

Starter units consist of four standard angle posts, *two left-to-right standard double rivet angle/channel beams per level and two front-to-back standard double rivet angle beams per level.

Adder units consist of two standard T-Posts, *two left-to-right standard double rivet angle/channel beams per level and two front-to-back standard double rivet angle beams per level. *Channel beam units are provided with left-to-right double rivet angle beams at bottom level.

RECORD STORAGE UNITS

Hallowell

www.Hallowell-List.com

RIVETWELL™ SHELVING

RECORD STORAGE UNITS								
Width	Depth	Height	Levels	No. of boxes	Starter Model No.	Adder Model No.	Particle Board Decking	EX-Deck Steel Decking
42"	15"	60"	3	18	RS421560-3S	RS421560-3A	HPB4215	HEZD4215
	30"	60"	3	36	RS423060-3S	RS423060-3A	HPB4230	HEZD4230
69"	15"	60"	3	30	RS691560-3S	RS691560-3A	HPB6915	HEZD6915
	30"	60"	3	60	RS693060-3S	RS693060-3A	HPB6930	HEZD6930
42"	15"	84"	4	24	RS421584-4S	RS421584-4A	HPB4215	HEZD4215
	30"	84"	4	48	RS423084-4S	RS423084-4A	HPB4230	HEZD4230
69"	15"	84"	4	40	RS691584-4S	RS691584-4A	HPB6915	HEZD6915
	30"	84"	4	80	RS693084-4S	RS693084-4A	HPB6930	HEZD6930
42"	15"	108"	5	30	RS4215108-5S	RS4215108-5A	HPB4215	HEZD4215
	30"	108"	5	60	RS4230108-5S	RS4230108-5A	HPB4230	HEZD4230
69"	15"	108"	5	50	RS6915108-5S	RS6915108-5A	HPB6915	HEZD6915
	30"	108"	5	100	RS6930108-5S	RS6930108-5A	HPB6930	HEZD6930

Be sure to order one each of particle board or EZ-Deck steel decking per level.
 *The above units do not include record storage boxes.

Hallowell Record Storage Boxes are 12" w x 15" d x 10" h and are constructed of 200# test white corrugated. Includes double thickness bottoms and reinforced carry handles. Must be ordered in lots of 20.



RECORD STORAGE BOXES
 Catalog No. Qty. Per Carton
 HRSB 20

ACCESS UNIT FROM FRONT OR BACK!



Record Storage Unit with 4 levels (80 Box unit)

COLOR SELECTION
 729 Parchment

5 DAY SHIPPING ON ALL IN-STOCK PRODUCTS

STOCK → **PROGRAM**

Quick Ship

AUTOMOTIVE STORAGE RACKS AND UNITS

THE FASTEST SHIPPING IN THE INDUSTRY...

TIRE STORAGE RACKS

Width	Depth	Height	Levels	*Tire Capacity	Starter Model No.	Adder Model No.
SINGLE ROW						
60"	21"	84"	3	24	TSS602184-3S	TSS602184-3A
	21"	120"	4	32	TSS6021120-4S	TSS6021120-4A
	21"	144"	5	40	TSS6021144-5S	TSS6021144-5A
	21"	192"	6	48	TSS6021192-6S**	TSS6021192-6A**
DOUBLE ROW						
60"	42"	84"	3	48	TSD602184-3S	TSD602184-3A
	42"	120"	4	64	TSD6021120-4S	TSD6021120-4A
	42"	144"	5	80	TSD6021144-5S	TSD6021144-5A
	42"	192"	6	96	TSD6021192-6S**	TSD6021192-6A**

(*)Based on average passenger tire (**) Supplied with heavy-duty posts

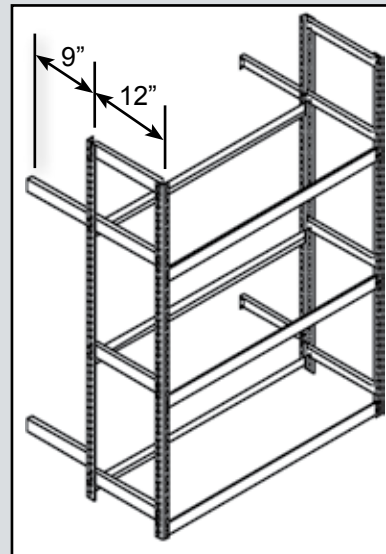

Tire Storage Rack

MUFFLER STORAGE UNITS

Width	Depth	Height	Levels	Starter Model No.	Adder Model No.	Particle Board Decking	
						Size	Part No.
48"	36"	84"	5	MS483684-5S	MS483684-5A	48" X 36"	HPB4836
96"	36"	84"	5	MS963684-5S	MS963684-5A	96" X 36"	HPB9636

Be sure to order one each of particle board decking per level.

HANGING TAILPIPE RACK

Width	Depth	Height	Starter Model No.
48"	18"	120"	HTP4818120
96"	18"	120"	HTP9618120

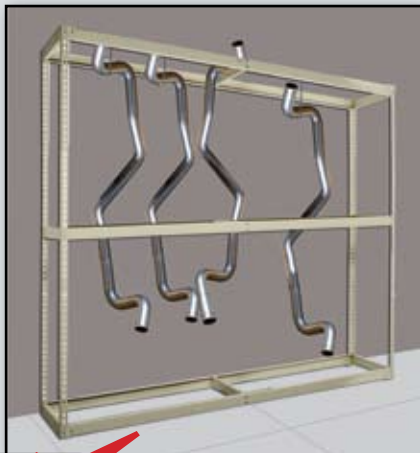

Hanging Tailpipe Rack



Tire Rack



Muffler Storage Rack

COLOR SELECTION

729 Parchment

RIVETWELL SHELVING COMPONENTS

Hallowell

www.Hallowell-List.com

RIVETWELL™ SHELVING COMPONENTS

PART DESCRIPTION	HEIGHT	STANDARD PART NO.	HEAVY-DUTY PART NO.
ANGLE POST		1-1/2" x 1-1/2" (14 ga)	1-7/8" x 1-7/8" (14 ga)
Punched for self adjustment on 1-1/2" centers	3'	APS03	-
	4'	APS04	-
	5'	APS05	-
	6'	APS06	APH06
	7'	APS07	APH07
	8'	APS08	APH08
	9'	APS09	APH09
	10'	APS10	APH10
	12'	APS12	APH12
	14'	APS14	APH14
	16'	APS16	APH16

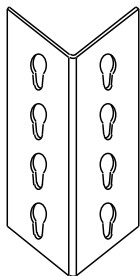

Note: For requirements above 16'-0" high, multiple posts can be spliced using PS05 post splice without compromising capacity.

PART DESCRIPTION	HEIGHT	STANDARD PART NO.	HEAVY-DUTY PART NO.
T-POST		3" x 1-7/8" (14 ga)	3-3/4" x 1-7/8" (14 ga)
Punched for self adjustment on 1-1/2" centers	3'	TPS03	TPH03
	4'	TPS04	TPH04
	5'	TPS05	TPH05
	6'	TPS06	TPH06
	7'	TPS07	TPH07
	8'	TPS08	TPH08
	9'	TPS09	TPH09
	10'	TPS10	TPH10
	12'	TPS12	TPH12
	14'	TPS14	TPH14
	16'	TPS16	TPH16

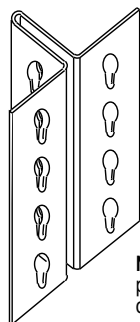

Note: For requirements above 16'-0" high, multiple posts can be spliced using PS05 post splice without compromising capacity.

PART DESCRIPTION	LENGTH	STANDARD PART NO.	HEAVY-DUTY PART NO.
DOUBLE RIVET ANGLE BEAM		2-3/4" x 1" (16 ga)	2-3/4" x 1" (14 ga)
Punched for self adjustment on 1-1/2" centers	2"	ABS12	-
	15"	ABS15	-
	18"	ABS18	-
	24"	ABS24	-
	30"	ABS30	-
	32"	ABS32	-
	36"	ABS36	-
	42"	ABS42	-
	48"	-	ABH48
	60"	-	ABH60
	69"	-	ABH69
	72"	-	ABH72
	84"	-	ABH84
	96"	-	ABH96

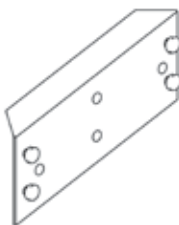

For left to right shelf and front to back shelf support. "R" is for beams punched to accept record storage box support

Denotes Stock Component

PART DESCRIPTION	LENGTH	STANDARD PART NO.	HEAVY-DUTY PART NO.
DOUBLE RIVET CHANNEL BEAM			1" x 2-3/4" (14 ga)
For left to right shelf support. Provides for a higher capacity than heavy-duty rivet angle beams.	48"	-	CBH48
	60"	-	CBH60
	69"	-	CBH69
	72"	-	CBH72
	84"	-	CBH84
	96"	-	CBH96

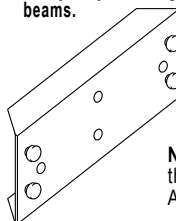

Note: When a bottom shelf is required to be at the bottom level, use a Heavy-Duty Double Rivet Angle Beam.

PART DESCRIPTION	LENGTH	STANDARD PART NO.	HEAVY-DUTY PART NO.
SINGLE RIVET BEAM		1" x 21/32" (14 ga)	1" x 21/32" (11 ga)
For use as left to right and front to back support. See Beam Load Table for capacity on page 73.	12"	SRBS12	-
	15"	SRBS15	-
	18"	SRBS18	-
	24"	SRBS24	-
	30"	SRBS30	-
	36"	SRBS36	SRBH36
	42"	SRBS42	SRBH42
	48"	SRBS48	SRBH48

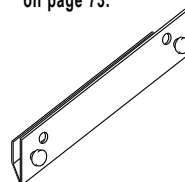

PART DESCRIPTION	LENGTH	STANDARD PART NO.	HEAVY-DUTY PART NO.
CENTER SUPPORT		2-3/4" x 1" (16 ga)	
Bolts to double rivet angle or channel beams to add support to decking and stabilize beams. Supplied with nuts and bolts for fast assembly. Use 1 per pair of beams up to 84", 2 per pair of 96" beams.	12"	CS12	-
	15"	CS15	-
	18"	CS18	-
	24"	CS24	-
	30"	CS30	-
	32"	CS32	-
	36"	CS36	-
	42"	CS42	-
	48"	CS48	-

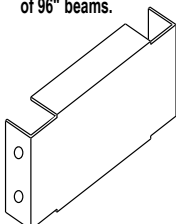

PART DESCRIPTION	LENGTH	STANDARD PART NO.	HEAVY-DUTY PART NO.
DOUBLE ROW AND TOP TIE		2-1/2" x 1/4" (14 ga)	
Use to space back-to-back units and to top-tie rows across aisle for added stability.	9-1/4"	-	DRTT09
	12-1/4"	-	DRTT12
	15-1/4"	-	DRTT15
	18-1/4"	-	DRTT18
	24-1/4"	-	DRTT24
	36-1/4"	-	DRTT36
	42-1/4"	-	DRTT42
	48-1/4"	-	DRTT48

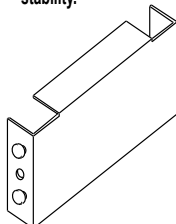

COLOR SELECTION

729 Parchment

5 DAY SHIPPING ON ALL IN-STOCK PRODUCTS

13

STOCK → **PROGRAM**



RIVETWELL SHELVING COMPONENTS

THE FASTEST SHIPPING IN THE INDUSTRY...

PART DESCRIPTION	LENGTH	STANDARD PART NO.	HEAVY-DUTY PART NO.
WALL TIE 2-1/2" x 1-1/4" (14 ga)			
Used to secure units to wall and provide space between wall and unit (Hardware to attach to wall not included).	9-1/4"	WT09	-
FOOT PLATE 1-1/2" x 1-1/2" x 3" (14 ga)			
For use in anchoring angle and tee posts to floor. (Hardware included for attaching posts-Hardware to anchor to the floor not included.) anchor holes are 3/8" diameter.	3"	FPR100	-
POST SPLICE 1-3/8" x 1-3/8" x 5" (11 ga)			
Used to extend post, attaches to outside of post. Order one per Angle Post, two per T-Post.	5"	PS05	-
TIE PLATE 3" x 3" (14 ga)			
Used for structural integrity of T-Post and to join Angle Post units side by side to insure proper row alignment.	NA	TP1	-
TIRE RACK BEAM 2-3/4" x 1" (14 ga)			
For left to right shelf support of tires. 9 degrees angle on supporting edge.	48" 60"	TRB48 TRB60	-

PART DESCRIPTION	LENGTH	STANDARD PART NO.	HEAVY-DUTY PART NO.
HANGER BAR 1-1/4" x 1-1/4" x 1-1/4" (14 ga)			
For hanging items between double rivet beams. One or more may be used per level.	36" 42" 48" 60"	HB 36 HB 42 HB 48 HB 60	- - - -
DECK OVER GRATING SUPPORT 3-12" x 1-13/16" x 2-3/16" (11 ga)			
Provides secure support for grating when decking over entire installation.	36" 48" 60" 69" 72"	- - - - -	DOGS36 DOGS48 DOGS60 DOGS69 DOGS72
DOWN AISLE GRATING SUPPORT 3-12" x 1-13/16" x 1-15/16" (11 ga)			
Attaches to unit front between rows to provide support for grating on 2-level rivetwell installations. For maximum aisle width of 48". Use a minimum of 3 screws per support. 9 degree angle on top edge.	36" 48" 60" 69" 72"	- - - - -	DAGS36 DAGS48 DAGS60 DAGS69 DAGS72
BEAM CLEAT 1-1/2" x 1"-1/2" x 3" (14 ga) 1-1/2" x 1"-1/2" x 3" (14 ga)			
An economical way to add units. Not recommended for heavy loads.	3"	BC-L	BC-R
SLOTTED ANGLE CLEAT 1-1/2" x 1"-1/2" x 3" (14 ga) 1-1/2" x 1"-1/2" x 3" (14 ga)			
For use where slotted angle pieces must be joined, such as special grating supports and top ties.	3"	SAC-L	SAC-R

Denotes Stock Component

COLOR SELECTION

729 Parchment

RIVETWELL SHELVING COMPONENTS

Hallowell

www.Hallowell-List.com

RIVETWELL™ SHELVING COMPONENTS

PART DESCRIPTION	LENGTH	STANDARD PART NO.	HEAVY-DUTY PART NO.
DOUBLE RIVET Z-BEAM (STANDARD) 2-1/8" x 7/8" (14 ga)			
For front to back and left to right. allows particle board decking to sit flush with top of beam.	12"	ZBS12	-
	15"	ZBS15	-
	18"	ZBS18	-
	24"	ZBS24	-
	30"	ZBS30	-
	36"	ZBS36	-
	42"	ZBS42	-
	48"	ZBS48	-
60"	ZBS60	-	

PART DESCRIPTION	LENGTH	STANDARD PART NO.	HEAVY-DUTY PART NO.
DOUBLE RIVET Z-BEAM (HEAVY-DUTY) 2-1/8" x 7/8" (14 ga)			
For front to back and left to right. Allows particle board decking to sit flush with top of beam.	69"	-	ZBH69
	72"	-	ZBH72

PART DESCRIPTION	LENGTH	STANDARD PART NO.	HEAVY-DUTY PART NO.
CENTER SUPPORT FOR Z BEAMS 1-3/16" x 1-1/8" x 7/8" (11 ga)			
Use with Z-beams for additional decking support front to back.	24"	ZCS24	-
	30"	ZCS30	-
	36"	ZCS36	-
	42"	ZCS42	-
	48"	ZCS48	-

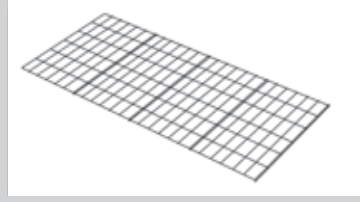
WIRE DECKING	
For use where additional ventilation is required. Contact factory for additional information.	

RIVETWELL DECKING

Nominal Size	Particle Board Decking	EZ-Deck Decking Steel
36" X 12"	HPB3612	HEZD3612
36" X 15"	HPB3615	HEZD3615
36" X 18"	HPB3618	HEZD3618
36" X 24"	HPB3624	HEZD3624
36" X 30"	HPB3630	HEZD3630
36" X 36"	HPB3636	HEZD3636
42" X 12"	HPB4212	HEZD4212
42" X 15"	HPB4215	HEZD4215
42" X 18"	HPB4218	HEZD4218
42" X 24"	HPB4224	HEZD4224
42" X 30"	HPB4230	HEZD4230
42" X 36"	HPB4236	HEZD4236
48" X 12"	HPB4812	HEZD4812
48" X 15"	HPB4815	HEZD4815
48" X 18"	HPB4818	HEZD4818
48" X 24"	HPB4824	HEZD4824
48" X 30"	HPB4830	HEZD4830
48" X 36"	HPB4836	HEZD4836
60" X 12"	HPB6012	HEZD6012
60" X 15"	HPB6015	HEZD6015
60" X 18"	HPB6018	HEZD6018
60" X 24"	HPB6024	HEZD6024
60" X 30"	HPB6030	HEZD6030
60" X 36"	HPB6036	HEZD6036
69" X 15"	HPB6915	HEZD6915
69" X 30"	HPB6930	HEZD6930
72" X 18"	HPB7218	HEZD7218
72" X 24"	HPB7224	HEZD7224
72" X 30"	HPB7230	HEZD7230
72" X 36"	HPB7236	HEZD7236
72" X 48"	HPB7248	HEZD7248
84" X 24"	HPB8424	HEZD8424
84" X 30"	HPB8430	HEZD8430
84" X 36"	HPB8436	HEZD8436
84" X 48"	HPB8448	HEZD8448
96" X 18"	HPB9618	HEZD9618
96" X 24"	HPB9624	HEZD9624
96" X 30"	HPB9630	HEZD9630
96" X 36"	HPB9636	HEZD9636
96" X 48"	HPB9648	HEZD9648

Particle Board Decking is type 1-M-2, 5/8" industrial grade and is in stock for immediate shipment. Order using the product number(s) listed. Be sure to order one each of particle board decking or EZ-Deck steel decking per level. All above decking is in stock. Additional sizes available on special order.

NOTE: EZ-Deck must be center supported on units 48" wide and wider.

COLOR SELECTION

 729 Parchment

STOCK → **PROGRAM**

PARTICLE BOARD & E-Z DECK CAPACITY RATINGS

THE FASTEST SHIPPING IN THE INDUSTRY...

Recommended safe use load table for 5/8" particle board and EZ-Deck steel decking allowable uniformly distributed static live loads for deck material

Size (inches) W x D	Particle Board Decking	EZ-Deck Steel Decking	2 Sides Supported		4 Sides Supported		4 Sides + Center Supported		4 Sides + 2 Center Supported	
			LOAD (lbs.)	DEFL (ins)	LOAD (lbs.)	DEFL (ins)	LOAD (lbs.)	DEFL (ins)	LOAD (lbs.)	DEFL (ins)
36x12	HPB3612	HEZD3612	425	0.06	675	0.08				
36x18	HPB3618	HEZD3618	400	0.17	550	0.18				
36x24	HPB3624	HEZD3624	305	0.30	435	0.23				
36x30	HPB3630	HEZD3630	250	0.47	385	0.32				
36x36	HPB3636	HEZD3636	150	0.50	180	0.39				
42x12	HPB4212	HEZD4212	490	0.06	755	0.08				
42x18	HPB4218	HEZD4218	460	0.17	600	0.18				
42x24	HPB4224	HEZD4224	355	0.30	500	0.29				
42x30	HPB4230	HEZD4230	300	0.47	410	0.36				
42x36	HPB4236	HEZD4236	175	0.50	385	0.45				
48x12	HPB4812	HEZD4812	560	0.06	850	0.08	1160	0.08		
48x18	HPB4818	HEZD4818	525	0.17	635	0.18	770	0.10		
48x24	HPB4824	HEZD4824	405	0.30	530	0.30	700	0.11		
48x30	HPB4830	HEZD4830	325	0.47	440	0.40	705	0.12		
48x36	HPB4836	HEZD4836	200	0.50	400	0.50	755	0.12		
48x48	HPB4848	HEZD4848	85	0.50	275	0.50	920	0.13		
60x18	HPB6018	HEZD6018	660	0.17	735	0.18	835	0.12	1140	0.08
60x24	HPB6024	HEZD6024	505	0.30	615	0.32	700	0.15	1180	0.10
60x30	HPB6030	HEZD6030	410	0.47	520	0.46	650	0.16	1324	0.11
60x36	HPB6036	HEZD6036	250	0.50	380	0.50	665	0.17	1520	0.12
60x48	HPB6048	HEZD6048	105	0.50	230	0.50	750	0.18	2000	0.14
69x15	HPB6915	HEZD6915	900	0.11	950	0.12	1150	0.12	1250	0.11
69x30	HPB6930	HEZD6930	470	0.50	600	0.50	670	0.20	1220	0.13
72x18	HPB7218	HEZD7218	800	0.17	850	0.17	1000	0.15	1200	0.10
72x24	HPB7224	HEZD7224	605	0.30	680	0.31	770	0.19	1135	0.12
72x30	HPB7230	HEZD7230	500	0.47	610	0.50	680	0.21	1200	0.14
72x36	HPB7236	HEZD7236	300	0.50	390	0.50	655	0.23	1325	0.16
72x48	HPB7248	HEZD7248	130	0.50	215	0.50	685	0.25	1670	0.18
84x24	HPB8424	HEZD8424	705	0.30	765	0.31	870	0.23	1150	0.15
84x30	HPB8430	HEZD8430	570	0.47	650	0.49	735	0.27	1150	0.18
84x36	HPB8436	HEZD8436	355	0.50	415	0.50	670	0.29	1210	0.20
84x48	HPB8448	HEZD8448	150	0.50	215	0.50	660	0.33	1460	0.23
96x18	HPB9618	HEZD9618	1050	0.17	1115	0.17	1300	0.18	1500	0.15
96x24	HPB9624	HEZD9624	810	0.30	850	0.31	1000	0.26	1200	0.18
96x30	HPB9630	HEZD9630	655	0.47	710	0.49	800	0.32	1180	0.20
96x36	HPB9636	HEZD9636	405	0.50	450	0.50	710	0.36	1150	0.24

NOTE: The above load chart refers to the deck materials only. Particle board decking is 5/8" industrial grade type 1-M-2. EZ-Deck steel decking is 22 gauge galvanized sheet steel fabricated in 6" deep channel planks (models listed above include multiple planks to meet unit depth). 15" deep Ez-Deck will be shipped in two (2) 7 1/2" deep planks. The allowable shelf load capacity may be reduced due to allowable post and / or beam capacities. Specific deflection limits may also reduce the shelf load capacity. **NOTE: EZ-Deck must be center supported on units 48" wide and wider.**

Particle Board Decking

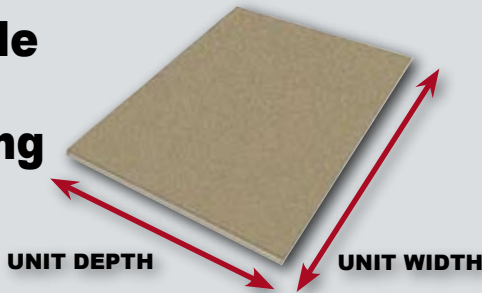

EZ-Deck Steel Decking

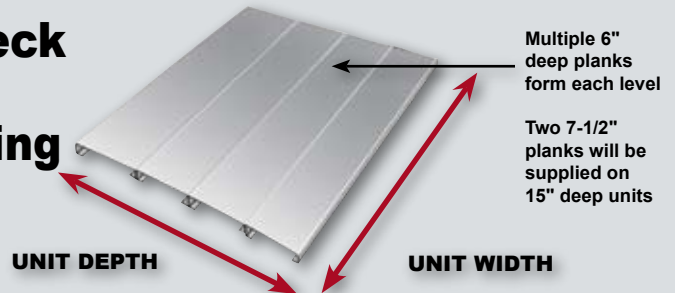

NOTE: EZ-Deck steel decking is for use with double rivet units **ONLY**.



POST CAPACITY CHART

Recommended safe loads (per post) for use only where seismic forces are not a factor

BEAM SPACING	STD. ANGLE POST CAPACITY	HEAVY ANGLE POST CAPACITY
12"	1530	1735
18"	1520	1720
24"	1510	1695
30"	1490	1680
36"	1350	1660
42"	990	1560
48"	755	1195

BEAM SPACING	STANDARD/HEAVY-DUTY T-POST CAPACITY
12"	5045
18"	4965
24"	4850
30"	4705
36"	4525
42"	4315
48"	4075

Post capacities are based on the maximum vertical distance between left-to-right beams or front-to-back beams, whichever is greater. In single rivet beam units, the vertical distance between front-to-back beams will usually govern. Tie plates must be spaced no more than 48 inches apart to insure structural stability when joining angle post together. All units require tie plates at top and bottom.

The above capacities are not intended for use when designing multi-level systems or for specific requirements where seismic forces are a factor. For specific multi-level or seismic requirements contact your Hallowell Sales Manager.

BEAM LOAD TABLE (CAPACITY PER PAIR)					
Recommended safe use allowable uniformly distributed hand loaded static beam loads					
	WITHOUT CENTER. SUPTS.(***)			WITH CENTER. SUPTS.(*)	
	LENGTH (IN.)	CAPACITY (LBS.)	DEFLECTION (IN.)	CAPACITY (LBS.)	DEFLECTION (IN.)
SINGLE RIVET SHELF BEAMS					
STANDARD BEAM	36	350	0.25	-	-
	42	300	0.30	-	-
	48	250	0.34	-	-
HEAVY DUTY BEAM	36	600	0.25	-	-
	42	550	0.30	-	-
	48	500	0.34	-	-
DOUBLE RIVET ANGLE BEAMS					
STANDARD BEAM	36	1000	***	-	-
	42	780	***	-	-
	48	500	***	875*	0.12
HEAVY DUTY BEAM	48	750	***	1400**	0.16
	60	600	***	1200	0.25
	69	525	***	1050	0.33
	72	500	***	1000	0.36
	84	-	-	840	0.49
	96	-	-	620	0.53
DOUBLE RIVET CHANNEL BEAMS					
	60	-	-	2240	0.23
	72	-	-	1850	0.33
	84	-	-	1600	0.45
	96	-	-	1400	0.59
DOUBLE RIVET Z-BEAM					
	48	1250	-	1750	-
	60	750	-	1000	-
	69	600	-	1000	-
	72	600	-	1000	-

DESIGN CRITERIA:

All units must have a full perimeter of double rivet beams at the top and bottom to insure a stable and rigid unit. All units using single rivet beams 10'0" to 18'0" in height, require an additional double rivet perimeter beam level located approximately in the middle of the unit.

All single rivet beam units must have one (1) intermediate pair of front to back beams for 7'0" and 8'0" high units and (2) intermediate pair of front to back beams for 9'0" high units. For 10'0" to 18'0" high units refer to the above paragraph.

DO NOT exceed 48" between front to back beams. Single Rivet and Double Rivet Front-to-Back Beams may be common when using T-Posts on units up to 8' high.

All intermediate single rivet levels over 24 inches deep must also have single rivet beams supporting the particle board front to back.

All double rivet beam units must have front to back beams at each shelf level.

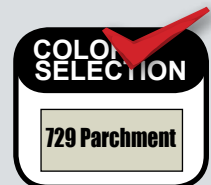

(*) One (1) support per pair of beams except 96" which have two (2) supports
 (**) Refer to shelf load capacities for beam capacities when depth is 30", 36" and 48".
 (***) Beam rotation is less than 5 degrees.



Hallowell Industrial Grade Steel Shelving

Hi-Tech shelving is a complete shelving line with the strength needed to handle most industrial applications and versatility for today's modern facilities. Every shelving unit is designed and engineered to meet the highest standards.

A full complement of accessories including full dividers, partial dividers, label holders, swinging doors, post splices for multilevel systems and foot plates are available to complete your system.



Quick Ship

5 DAY SHIPPING ON ALL IN-STOCK SHELVING





BOX FORMED SHELVES

- Tubular welded box beam front and rear for maximum strength
- Exclusive triple bend side flanges for added strength
- Lapped and welded corners
- Top of shelf is punched to accept shelf dividers



ANGLE BACK POSTS & T-POSTS

- Roll formed into a unique angle shape for maximum strength
- The long leg is punched on 1-1/2" centers to allow independent shelf adjustment
- Angle Posts can be used in place of Beaded Front Posts if desired



BEADED FRONT POSTS

- Beaded for strength
- Flush to permit straight-in/straight-out shelf installation, shelf changing and full use of shelf width
- Punched on 1-1/2" centers to allow independent shelf adjustment



H-POSTS

- Designed for high-density applications
- More than twice the capacity of standard posts
- Used at front and back
- Used with standard Hi-Tech components



ONE PIECE SHELF CLIP

- Four sturdy and compact clips per shelf
- Keys firmly into post slots to hold shelves securely in place
- Fits Beaded Front, Angle Back Posts and T-Posts
- Non-Intrusive clip sits flush with inside edge of front posts

ACCESSORIES



Base Strips
Close bottom to prevent debris accumulation



Swinging Doors
Allow cabinet-style storage



Shelf Dividers
For organized storage

OPEN SHELVING MEDIUM, HEAVY AND EXTRA HEAVY-DUTY

HI-TECH™ SHELVING



STARTER UNIT



ADDER UNIT



5 SHELF UNIT



6 SHELF UNIT



8 SHELF UNIT

W	D	H		5-Shelf Unit Cat No.	6-Shelf Unit Cat No.	8-Shelf Unit Cat No.	Shelf Capacity*
Medium-Duty							
36	12	87	Starter	4510-12	4511-12	4513-12	500*
36	12	87	Adder	A4510-12	A4511-12	A4513-12	500*
36	18	87	Starter	4510-18	4511-18	4513-18	500*
36	18	87	Adder	A4510-18	A4511-18	A4513-18	500*
36	24	87	Starter	4510-24	4511-24	4513-24	500*
36	24	87	Adder	A4510-24	A4511-24	A4513-24	500*
48	12	87	Starter	4710-12	4711-12	4713-12	375*
48	12	87	Adder	A4710-12	A4711-12	A4713-12	375*
48	18	87	Starter	4710-18	4711-18	4713-18	375*
48	18	87	Adder	A4710-18	A4711-18	A4713-18	375*
48	24	87	Starter	4710-24	4711-24	4713-24	350*
48	24	87	Adder	A4710-24	A4711-24	A4713-24	350*
Heavy-Duty							
36	12	87	Starter	5510-12	5511-12	5513-12	800*
36	12	87	Adder	A5510-12	A5511-12	A5513-12	800*
36	18	87	Starter	5510-18	5511-18	5513-18	800*
36	18	87	Adder	A5510-18	A5511-18	A5513-18	800*
36	24	87	Starter	5510-24	5511-24	5513-24	800*
36	24	87	Adder	A5510-24	A5511-24	A5513-24	800*
48	12	87	Starter	5710-12	5711-12	5713-12	400*
48	12	87	Adder	A5710-12	A5711-12	A5713-12	400*
48	18	87	Starter	5710-18	5711-18	5713-18	450*
48	18	87	Adder	A5710-18	A5711-18	A5713-18	450*
48	24	87	Starter	5710-24	5711-24	5713-24	500*
48	24	87	Adder	A5710-24	A5711-24	A5713-24	500*
Extra Heavy-Duty							
36	12	87	Starter	7510-12	7511-12	7513-12	1100*
36	12	87	Adder	A7510-12	A7511-12	A7513-12	1100*
36	18	87	Starter	7510-18	7511-18	7513-18	1200*
36	18	87	Adder	A7510-18	A7511-18	A7513-18	1200*
36	24	87	Starter	7510-24	7511-24	7513-24	1250*
36	24	87	Adder	A7510-24	A7511-24	A7513-24	1250*
48	12	87	Starter	7710-12	7711-12	7713-12	750*
48	12	87	Adder	A7710-12	A7711-12	A7713-12	750*
48	18	87	Starter	7710-18	7711-18	7713-18	900*
48	18	87	Adder	A7710-18	A7711-18	A7713-18	900*
48	24	87	Starter	7710-24	7711-24	7713-24	900*
48	24	87	Adder	A7710-24	A7711-24	A7713-24	900*
Additional Shelves				Medium-Duty Cat No.	Heavy-Duty Cat No.	Extra Heavy-Duty Cat No.	
36	12			5135-3612	5138-3612	5139-3612	See Above
36	18			5135-3618	5138-3618	5139-3618	See Above
36	24			5135-3624	5138-3624	5139-3624	See Above
48	12			5135-4812	5138-4812	5139-4812	See Above
48	18			5135-4818	5138-4818	5139-4818	See Above
48	24			5135-4824	5138-4824	5139-4824	See Above

* Shelf capacity based on a factor of 1.65

Color for all components 725 Hallowell Gray. Optional colors are available at a nominal charge, additional lead times apply.

OPEN UNITS: Starter units include two beaded front posts, two angle back posts, one pair back sway braces, two pair side sway braces and 5-8 shelves. Adder units include one beaded front post, two angle back posts, one pair back sway braces, one pair side sway braces and 5-8 shelves.

COLOR SELECTION

725
HALLOWELL GRAY
(HG)

CLOSED SHELVING MEDIUM, HEAVY AND EXTRA HEAVY-DUTY

Hallowell
www.Hallowell-List.com

HI-TECH™ SHELVING

W	D	H		5-Shelf Unit Cat No.	6-Shelf Unit Cat No.	8-Shelf Unit Cat No.	Shelf Capacity*
Medium-Duty							
36	12	87	Starter	4520-12	4521-12	4523-12	500*
36	12	87	Adder	A4520-12	A4521-12	A4523-12	500*
36	18	87	Starter	4520-18	4521-18	4523-18	500*
36	18	87	Adder	A4520-18	A4521-18	A4523-18	500*
36	24	87	Starter	4520-24	4521-24	4523-24	500*
36	24	87	Adder	A4520-24	A4511-24	A4523-24	500*
48	12	87	Starter	4720-12	4721-12	4723-12	375*
48	12	87	Adder	A4720-12	A4721-12	A4723-12	375*
48	18	87	Starter	4720-18	4721-18	4723-18	375*
48	18	87	Adder	A4720-18	A4721-18	A4723-18	375*
48	24	87	Starter	4720-24	4721-24	4723-24	350*
48	24	87	Adder	A4720-24	A4721-24	A4723-24	350*
Heavy-Duty							
36	12	87	Starter	5520-12	5521-12	5523-12	800*
36	12	87	Adder	A5520-12	A5521-12	A5523-12	800*
36	18	87	Starter	5520-18	5521-18	5523-18	800*
36	18	87	Adder	A5520-18	A5521-18	A5523-18	800*
36	24	87	Starter	5520-24	5521-24	5523-24	800*
36	24	87	Adder	A5520-24	A5521-24	A5523-24	800*
48	12	87	Starter	5720-12	5721-12	5723-12	400*
48	12	87	Adder	A5720-12	A5721-12	A5723-12	400*
48	18	87	Starter	5720-18	5721-18	5723-18	450*
48	18	87	Adder	A5720-18	A5721-18	A5723-18	450*
48	24	87	Starter	5720-24	5721-24	5723-24	500*
48	24	87	Adder	A5720-24	A5721-24	A5723-24	500*
Extra Heavy-Duty							
36	12	87	Starter	7520-12	7521-12	7523-12	1100*
36	12	87	Adder	A7520-12	A7521-12	A7523-12	1100*
36	18	87	Starter	7520-18	7521-18	7523-18	1200*
36	18	87	Adder	A7520-18	A7521-18	A7523-18	1200*
36	24	87	Starter	7520-24	7521-24	7523-24	1250*
36	24	87	Adder	A7520-24	A7521-24	A7523-24	1250*
48	12	87	Starter	7720-12	7721-12	7723-12	750*
48	12	87	Adder	A7720-12	A7721-12	A7723-12	750*
48	18	87	Starter	7720-18	7721-18	7723-18	900*
48	18	87	Adder	A7720-18	A7721-18	A7723-18	900*
48	24	87	Starter	7720-24	7721-24	7723-24	900*
48	24	87	Adder	A7720-24	A7721-24	A7723-24	900*
Additional Shelves				Medium-Duty Cat No.	Heavy-Duty Cat No.	Extra Heavy-Duty Cat No.	
36	12			5135-3612	5138-3612	5139-3612	See Above
36	18			5135-3618	5138-3618	5139-3618	See Above
36	24			5135-3624	5138-3624	5139-3624	See Above
48	12			5135-4812	5138-4812	5139-4812	See Above
48	18			5135-4818	5138-4818	5139-4818	See Above
48	24			5135-4824	5138-4824	5139-4824	See Above

* Shelf capacity based on a factor of 1.65

Color for all components 725 Hallowell Gray. Optional colors are available at a nominal charge, additional lead times apply.

CLOSED UNITS: Starter units include two beaded front posts, two angle back posts, one back panel assembly, two side panel assemblies and 5-8 shelves. Adder units include one beaded front post, two angle back posts, one back panel, one side panel and 5-8 shelves.



STARTER UNIT



ADDER UNIT



5 SHELF UNIT



6 SHELF UNIT



8 SHELF UNIT

5 DAY SHIPPING ON ALL IN-STOCK PRODUCTS

21

BEADED FRONT POSTS (14 gauge)



True flush construction. Slotted on 1-1/2" centers to permit easy shelf adjustment. Multiple posts can be spliced for added height.

Part No	Width	Depth	Height
5002-3W	11/16"	2-9/16"	3'3"
5002-6W	11/16"	2-9/16"	6'3"
5002-7W	11/16"	2-9/16"	7'3"
5002-8W	11/16"	2-9/16"	8'3"
5002-10W	11/16"	2-9/16"	10'3"
5002-12W	11/16"	2-9/16"	12'3"
5002-14W	11/16"	2-9/16"	14'3"
5002-16W	11/16"	2-9/16"	16'3"

ANGLE BACK POSTS (14 gauge)



Angles for single or end units. Slotted on 1-1/2" centers to permit easy shelf adjustment. Multiple posts can be spliced for added height.

Part No	Width	Depth	Height
5004-3	1-3/16"	2-5/16"	3'3"
5004-6	1-3/16"	2-5/16"	6'3"
5004-7	1-3/16"	2-5/16"	7'3"
5004-8	1-3/16"	2-5/16"	8'3"
5004-10	1-3/16"	2-5/16"	10'3"
5004-12	1-3/16"	2-5/16"	12'3"
5004-14	1-3/16"	2-5/16"	14'3"
5004-16	1-3/16"	2-5/16"	16'3"

T- POSTS (14 gauge)



Constructed by spot welding two back posts together. For use when adjoining models are added to form a continuous row. Multiple posts can be spliced for added height.

Part No	Width	Depth	Height
5006-3	2-3/8"	2-5/16"	3'3"
5006-6	2-3/8"	2-5/16"	6'3"
5006-7	2-3/8"	2-5/16"	7'3"
5006-8	2-3/8"	2-5/16"	8'3"
5006-10	2-3/8"	2-5/16"	10'3"
5006-12	2-3/8"	2-5/16"	12'3"
5006-14	2-3/8"	2-5/16"	14'3"
5006-16	2-3/8"	2-5/16"	16'3"

POST SPLICE CHANNELS (16 gauge)

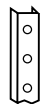

A channel formed internal splice. Used to splice beaded front posts for added height. Also, to splice back posts and T-posts

Part No	Width	Depth	Height
5009	-	-	-

BACK SWAY BRACES (11 gauge)

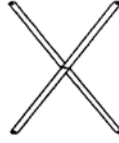

1" x 11 ga. steel strip with safety edges. One pair of braces are bolted together at center to form an "X". Ends are rounded and pierced for mounting to rear posts.

See technical data on page 67 for bracing information

Part No	Width	Depth	Height
5342-44*	36"	-	-
5342-55*	42"	-	-
5342-55*	48"	-	-

*Also available from stock in Platinum color

SIDE SWAY BRACES (11 gauge)



1" x 11 ga. steel strip with safety edges. One pair of braces are bolted together at the center to form an "X". Ends are rounded and pierced for attaching to front and rear posts in the side position. See technical data on page 53 for bracing information.

Part No	Width	Depth	Height
5344-12	-	12"	-
5344-15	-	15"	-
5344-18	-	18"	-
5344-24	-	24"	-
5344-30	-	30"	-
5344-32	-	32"	-
5344-36	-	36"	-

BACK PANELS (24 gauge)

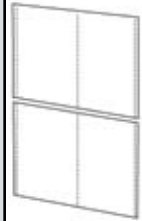

Two piece sections punched on 1" centers at vertical edges and center for mounting on back of posts and shelves in models up to 48" wide.

Part No	Width	Depth	Height
5110-3603	36"	-	3'3"
5110-3606	36"	-	6'3"
5110-3607	36"	-	7'3"
5110-4203	42"	-	3'3"
5110-4206	42"	-	6'3"
5110-4207	42"	-	7'3"
5110-4803	48"	-	3'3"
5110-4806	48"	-	6'3"
5110-4807	48"	-	7'3"

NOTE: Backs greater than 3'-3" will be shipped in multiple pieces.

Denotes Stock Component

*Also available from stock in Platinum color

NOTE: For requirements above 16'-3" high, multiple posts can be spliced using 5009 post splice channels without compromising capacity. See page 67 for unit load and sway brace information.
Color for all components: 725 Hallowell Gray

COLOR SELECTION

725
HALLOWELL GRAY
(HG)

COMPONENTS & DIMENSIONS

Hallowell

www.Hallowell-List.com

HI-TECH™ SHELVING

BACK PANEL CLIPS

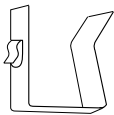

Formed to fit bottom flange of standard shelf and tabbed to pick up holes in center of back panel section. Holds back panel to shelf and prevents panel bowing.

Part No	Width	Depth	Height
5120	-	-	-

SIDE PANELS (24 gauge)



Two piece panels are bolted to standard Beaded, Angle and Tee Posts when solid sides are required.

Part No	Width	Depth	Height
5093-1203	-	12"	3'3"
5093-1206	-	12"	6'3"
5093-1207	-	12"	7'3"
5093-1507	-	15"	7'3"
5093-1803	-	18"	3'3"
5093-1806	-	18"	6'3"
5093-1807	-	18"	7'3"
5093-2403	-	24"	3'3"
5093-2406	-	24"	6'3"
5093-2407	-	24"	7'3"
5093-3007	-	30"	7'3"
5093-3607	-	36"	7'3"

NOTE: Sides greater than 3'-3" will be shipped in multiple pieces.

SHELVES

Roll formed rectangular tubular shaped front and rear edges with return flanges welded on 3" centers to underside of shelf. Sides are triple flanged. All four corners are lapped and welded. Top pierced to accept dividers.

MEDIUM-DUTY BOX BEAM SHELVES (CLASS O)

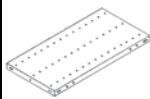

Part No	Width	Depth	Capacity Per Shelf
5135-3612	36"	12"	500 lbs
5135-3615	36"	15"	500 lbs
5135-3618	36"	18"	500 lbs
5135-3624	36"	24"	500 lbs
5135-4812	48"	12"	375 lbs
5135-4818	48"	18"	375 lbs
5135-4824	48"	24"	375 lbs

HEAVY-DUTY BOX BEAM SHELVES (CLASS 1)

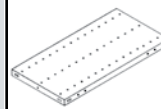

Part No	Width	Depth	Capacity Per Shelf
5138-3612	36"	12"	800 lbs
5138-3615	36"	15"	800 lbs
5138-3618*	36"	18"	800 lbs
5138-3624*	36"	24"	800 lbs
5138-3630	36"	30"	500 lbs
5138-3636	36"	36"	500 lbs
5138-4212	42"	12"	600 lbs
5138-4215	42"	15"	600 lbs
5138-4218	42"	18"	600 lbs
5138-4224	42"	24"	600 lbs
5138-4230	42"	30"	625 lbs
5138-4232	42"	32"	575 lbs
5138-4236	42"	36"	475 lbs
5138-4812	48"	12"	400 lbs
5138-4815	48"	15"	425 lbs
5138-4818*	48"	18"	450 lbs
5138-4824*	48"	24"	500 lbs
5138-4830	48"	30"	500 lbs
5138-4836	48"	36"	500 lbs

*Also available from stock in Platinum color

EXTRA HEAVY-DUTY BOX BEAM SHELVES (CLASS 2)

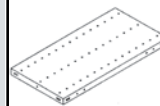

Part No	Width	Depth	Capacity Per Shelf
5139-3612	36"	12"	1100 lbs
5139-3615	36"	15"	1100 lbs
5139-3618*	36"	18"	1200 lbs
5139-3624*	36"	24"	1250 lbs
5139-3630	36"	30"	900 lbs
5139-3636	36"	36"	900 lbs
5139-4212	42"	12"	1100 lbs
5139-4215	42"	15"	1100 lbs
5139-4218	42"	18"	1050 lbs
5139-4224	42"	24"	900 lbs
5139-4230	42"	30"	1000 lbs
5139-4232	42"	32"	900 lbs
5139-4236	42"	36"	900 lbs
5139-4812	48"	12"	750 lbs
5139-4815	48"	15"	750 lbs
5139-4818*	48"	18"	900 lbs
5139-4824*	48"	24"	900 lbs
5139-4830	48"	30"	750 lbs
5139-4836	48"	36"	750 lbs

*Also available from stock in Platinum color

SHELF CLIP (13 gauge)



One-piece zinc plated compression clip fits snugly against side of posts to hold shelves in place. Four required per shelf.

Part No	Width	Depth	Capacity Per Shelf
5133	-	-	-

Denotes Stock Component

*Also available from stock in Platinum color

5 DAY SHIPPING ON ALL IN-STOCK PRODUCTS

23

BASE STRIPS (22 gauge)

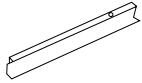

Shaped to fit directly between bottom shelf and floor. 2-15/16" high giving an overall base height including bottom shelf of 3".

Part No	Width	Depth	Height
5233-36	36"	-	2-15/16"
5233-42	42"	-	2-15/16"
5233-48	48"	-	2-15/16"

LABEL HOLDERS (20 gauge)



Pierced for attaching to front flange of shelves with top and bottom edges folded over to accommodate labels approximately 1" high.

Part No	Width	Depth	Height
5370-3601	36"	-	1"
5370-4201	42"	-	1"
5370-4801	48"	-	1"

WELDED END PANELS (14 ga posts & 24 ga side)

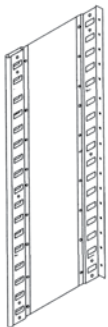

Sections consisting of beaded front post, angle back post and one-piece side panel. For individual models or starting and ending models in a continuous shelving row. Factory welded.

Part No	Width	Depth	Height
5092-1203	-	12"	3'3"
5092-1206	-	12"	6'3"
5092-1207	-	12"	7'3"
5092-1208	-	12"	8'3"
5092-1210	-	12"	10'3"
5092-1507	-	15"	7'3"
5092-1803	-	18"	3'3"
5092-1806	-	18"	6'3"
5092-1807	-	18"	7'3"
5092-1808	-	18"	8'3"
5092-1810	-	18"	10'3"
5092-2403	-	24"	3'3"
5092-2406	-	24"	6'3"
5092-2407	-	24"	7'3"
5092-2408	-	24"	8'3"
5092-2410	-	24"	10'3"
5092-3007	-	30"	7'3"
5092-3607	-	36"	7'3"

NOTE: For requirements above 10'-3" high, multiple panels can be spliced using 5009 post splice channels without compromising capacity. See page 67 for unit load and sway brace information. Color for all components: 725 Hallowell Gray

SWINGING DOORS (WITH LOCKS)

Reinforced door / frame attaches to beaded front posts and opens quietly to a full 150°. Chrome finished handle with built-in grooved key cylinder lock. Positive 3-point locking. Universal clips (Part No. 5315) are required to mount doors on beaded front posts.



Part No	Width	Depth	Height
5300-3636	36"	-	36"
5300-3648	36"	-	48"
5300-3684	36"	-	84"
5300-4836	48"	-	36"
5300-4848	48"	-	48"
5300-4884	48"	-	84"

UNIVERSAL CLIP (WITH HARDWARE)



Available in sets of 6. One set required to mount swinging doors to beaded front posts.

Part No	Width	Depth	Height
5315	-	-	-

FOOT PLATES



11 gauge with 14 gauge mounting bracket welded to top for bolting to post. Has 7/16" diameter hole for floor anchor bolts. Use same shim as H-Posts.

Part No	Width	Depth	Height
5050	2-1/4"	3-1/2"	-

WELDED T-PANELS (14 ga posts & 24 ga side)

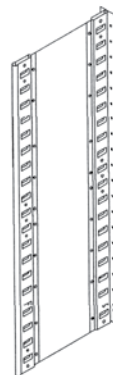

Sections consisting of beaded front post, back T-Post and one-piece side panel. For use when adjoining models are added to form a continuous shelving row. Factory welded.

Part No	Width	Depth	Height
5094-1203	-	12"	3'3"
5094-1206	-	12"	6'3"
5094-1207	-	12"	7'3"
5094-1208	-	12"	8'3"
5094-1210	-	12"	10'3"
5094-1507	-	15"	7'3"
5094-1803	-	18"	3'3"
5094-1806	-	18"	6'3"
5094-1807	-	18"	7'3"
5094-1808	-	18"	8'3"
5094-1810	-	18"	10'3"
5094-2403	-	24"	3'3"
5094-2406	-	24"	6'3"
5094-2407	-	24"	7'3"
5094-2408	-	24"	8'3"
5094-2410	-	24"	10'3"
5094-3007	-	30"	7'3"
5094-3607	-	36"	7'3"

Denotes Stock Component

COLOR SELECTION

725 HALLOWELL GRAY (HG)

COMPONENTS & DIMENSIONS

Hallowell

www.Hallowell-List.com

HI-TECH™ SHELVING

BIN FRONT (18 gauge)

Offset type with bead at top and triple flange at bottom to telescope over shelf flange.



Part No	Width	Depth	Height
5220-3601	36"	-	1"
5220-3603	36"	-	3"
5220-4203	42"	-	3"
5220-4803	48"	-	3"

PARTIAL DIVIDERS (22 gauge)

Offset type with bead at top and triple flange at bottom to telescope over shelf flange.



Part No	Width	Depth	Height
5250-1202	-	12"	2"
5250-1204	-	12"	4"

H-POST SIDE SWAY BRACES (11 gauge)



Used with H-Posts only.

Part No	Width	Depth	Height
5341-12	-	12"	-
5341-15	-	15"	-
5341-18	-	18"	-
5341-24	-	24"	-
5341-30	-	30"	-
5341-36	-	36"	-

MULTI-LEVEL HIGH-RISE SHELVING SYSTEMS

Complete high-rise modular systems make it easy to create that perfect shelving solution to maximize space in any facility.

Consult your sales representative for more information or contact us at: info@Hallowell-List.com

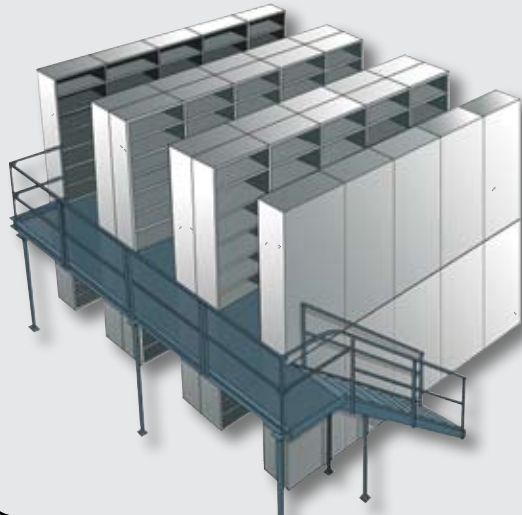

FULL DIVIDERS (20 gauge)

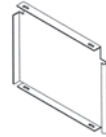

Front edge beaded. Top, bottom and rear are flanged.

Part No	Width	Depth	Height
5240-1206	-	12"	6"
5240-1209	-	12"	9"
5240-1212	-	12"	12"
5240-1806	-	18"	6"
5240-1809	-	18"	9"
5240-1812	-	18"	12"
5240-2406	-	24"	6"
5240-2409	-	24"	9"
5240-2412	-	24"	12"

H-POSTS (14 gauge)

Used for high-density shelving requirements. Used with standard Hi-Tech shelving components side sway braces (5341). Order H-Posts front and back. **Minimum order 100 posts.**



Part No	Width	Depth	Height
5003-7	1-1/2"	2-15/16"	7'3"
5003-8	1-1/2"	2-15/16"	8'3"
5003-10	1-1/2"	2-15/16"	10'3"
5003-12	1-1/2"	2-15/16"	12'3"
5003-14	1-1/2"	2-15/16"	14'3"
5003-16	1-1/2"	2-15/16"	16'3"

H-POST SPLICES (16 gauge)

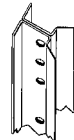

Used to splice H-posts for added height requirements

Part No	Width	Depth	Height
5010 (Plated)	-	-	9-3/4"

H-POST FOOT PLATE (Heavy-Duty)



Mounting bracket welded to top for bolting inside H-Posts.

Part No	Width	Depth	Height
5015 (Plated)	4"	3-1/2"	3/8"

H-POST SHIM PLATE



Fits under foot plate (Part no. 5015) for leveling.

Part No	Width	Depth	Height
5016 (Plated)	4"	3-1/2"	1/16"

Denotes Stock Component

Denotes Marine Blue Stock Component

5 DAY SHIPPING ON ALL IN-STOCK PRODUCTS

25







STOCK → **PROGRAM**

Quick Ship

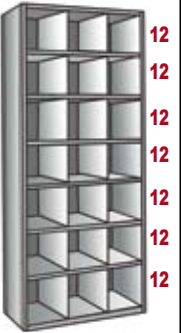
CLOSED METAL SHELVING BIN UNITS

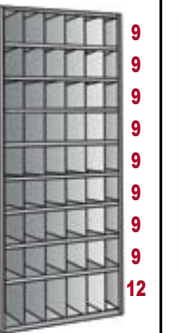
THE FASTEST SHIPPING IN THE INDUSTRY...

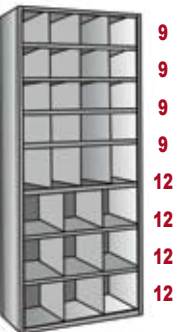
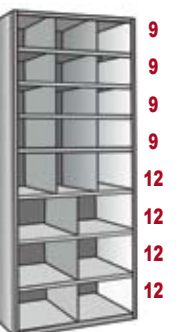
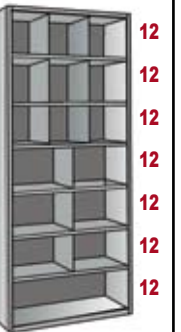
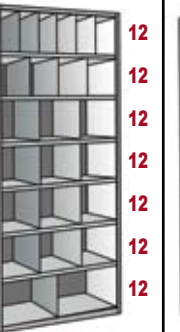
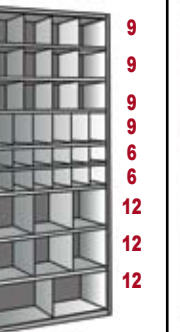
METAL BIN STORAGE SHELVING

						
	MODEL 5525	MODEL 5526	MODEL 5527	MODEL 5528	MODEL 5529	MODEL 5530
	OPENINGS SIZE	OPENINGS SIZE	OPENINGS SIZE	OPENINGS SIZE	OPENINGS SIZE	OPENINGS SIZE
SHELF DEPTH	14 18" x 12"	21 12" x 12"	32 9" x 9" 4 9" x 12"	48 6" x 9" 6 6" x 12"	66 6" x 6" 12 6" x 9"	48 6" x 9" 6 6" x 12" All with 3" high front bins
	STARTER	STARTER	STARTER	STARTER	STARTER	STARTER
12"	5525-12	5526-12	5527-12	5528-12	5529-12	5530-12
18"	5525-18	5526-18	5527-18	5528-18	5529-18	5530-18
24"	5525-24	5526-24	5527-24	5528-24	5529-24	5530-24
	ADDER	ADDER	ADDER	ADDER	ADDER	ADDER
12"	A5525-12	A5526-12	A5527-12	A5528-12	A5529-12	A-5530-12
18"	A5525-18	A5526-18	A5527-18	A5528-18	A5529-18	A-5530-18
24"	A5525-24	A5526-24	A5527-24	A5528-24	A5529-24	A-5530-24
						
	MODEL 5531	MODEL 5532	MODEL 5533	MODEL 5534	MODEL 5535	MODEL 5536
	OPENINGS SIZE	OPENINGS SIZE	OPENINGS SIZE	OPENINGS SIZE	OPENINGS SIZE	OPENINGS SIZE
SHELF DEPTH	16 9" x 9" 4 9" x 12" 9 12" x 12"	12 12" x 9" 3 12" x 12" 6 18" x 12"	9 12" x 12" 6 18" x 12" 1 36" x 12"	6 6" x 12" 4 9" x 12" 12 12" x 12" 2 18" x 12"	12 9" x 9" 6 6" x 9" 12 6" x 6" 6 12" x 12" 2 18" x 12"	21 12" x 12" All with 3" high front bins
	STARTER	STARTER	STARTER	STARTER	STARTER	STARTER
12"	5531-12	5532-12	5533-12	5534-12	5535-12	5536-12
18"	5531-18	5532-18	5533-18	5534-18	5535-18	5536-18
24"	5531-24	5532-24	5533-24	5534-24	5535-24	5536-24
	ADDER	ADDER	ADDER	ADDER	ADDER	ADDER
12"	A5531-12	A5532-12	A5533-12	A5534-12	A5535-12	A-5536-12
18"	A5531-18	A5532-18	A5533-18	A5534-18	A5535-18	A-5536-18
24"	A5531-24	A5532-24	A5533-24	A5534-24	A5535-24	A-5536-24

NOTES: • Starter & adder units are made up of the same components as shown on page 13 and include metal dividers to create each specific configuration and base strips.
 • 48" wide units are also available.
 • Size of openings is indicated by width x height.















• Color for all components is 725 Hallowell Gray

OPEN METAL SHELVING PLASTIC BIN UNITS

Hallowell®

www.Hallowell-List.com

PLASTIC BIN STORAGE SHELVING

					
MODEL	5570 (36" wide)	5571 (36" wide)	5572 (36" wide)	5573 (36" wide)	5574 (36" wide)
SHELF DEPTH	BINS SIZE 96 4.125" x 4"	BINS SIZE 72 4.125" x 6"	BINS SIZE 45 6.625" x 6"	BINS SIZE 24 11" x 7"	BINS SIZE 18 11" x 10"
	STARTER	STARTER	STARTER	STARTER	STARTER
12"	5570-12	5571-12	5572-12	-	-
18"	5570-18	5571-18	5572-18	-	-
24"	5570-24	-	-	5573-24	5574-24
	ADDER	ADDER	ADDER	ADDER	ADDER
12"	A5570-12	A5571-12	A5572-12	-	-
18"	A5570-18	A5571-18	A5572-18	-	-
24"	A5570-24	-	-	A5573-24	A5574-24
					
MODEL	5575 (36" wide)	5770 (48" wide)	5771 (48" wide)	5772 (48" wide)	5773 (48" wide)
SHELF DEPTH	BINS SIZE 10 16.5" x 11"	BINS SIZE 132 4.125" x 4"	BINS SIZE 99 4.125" x 6"	BINS SIZE 63 6.625" x 6"	BINS SIZE 32 11" x 7"
	STARTER	STARTER	STARTER	STARTER	STARTER
12"	-	5770-12	5771-12	5772-12	-
18"	-	5770-18	5771-18	5772-18	-
24"	5575-24	5770-24	-	-	5773-24
	ADDER	ADDER	ADDER	ADDER	ADDER
12"	-	A5770-12	A5771-12	A5772-12	-
18"	-	A5770-18	A5771-18	A5772-18	-
24"	A5575-24	A5770-24	-	-	A5773-24
					
MODEL	5774 (48" wide)		5580 (36" wide)	5581 (36" wide)	5582 (36" wide)
SHELF DEPTH	BINS SIZE 24 11" x 10"		BINS SIZE 3 11" x 7" 9 11" x 10" 4 16.5" x 11"	BINS SIZE 24 4.125" x 4" 6 11" x 7" 9 11" x 10"	BINS SIZE 16 4.125" x 4" 32 4.125" x 6" 20 6.625" x 6"
	STARTER		STARTER	STARTER	STARTER
12"	-		-	-	5582-12
18"	-		-	-	5582-18
24"	5774-24		5580-24	5581-24	-
	ADDER		ADDER	ADDER	ADDER
12"	-		-	-	A5582-12
18"	-		-	-	A5582-18
24"	A5774-24		A5580-24	A5581-24	-

NOTES: • Starter & adder units are made up of the same components as shown on page 12 and include plastic bins to create unit configurations.
• Color for all shelving components is 725 Hallowell Gray
• Size of bins is indicated by width x height.

COLOR
SELECTION

725
HALLOWELL GRAY
(HG)

HI-TECH™ H-POST

HALLOWELL® High Capacity Shelving

H-POST PROVIDES TWICE THE CAPACITY OF STANDARD POSTS

H-Post High capacity Shelving is ideal when additional strength is required for any shelving installation. It is also recommended for multi-level high-rise applications.

H-Posts are fabricated from 14 gauge cold rolled steel and formed into a unique tubular design to provide more than twice the load capacity compared to standard posts.



**USE WITH STANDARD
HI-TECH COMPONENTS**

Hallowell

www.Hallowell-List.com

HI-TECH™ H-POST SHELVING



H-POST

- Designed for high-density applications
- More than twice the capacity of standard posts
- Used at front and back
- Used with standard Hi-Tech components



BOX FORMED SHELVES

- Tubular welded box beam front and rear for maximum strength
- Exclusive triple bend side flanges for added strength
- Lapped and welded corners
- Top of shelf is punched to accept shelf dividers



ONE PIECE SHELF CLIP

- Each shelf requires four of these sturdy and compact clips
- Clips key firmly into post slots to hold shelves securely in place
- Also fits Beaded Front, Angle Back Posts and T-Posts
- Provides independent shelf positioning on 1-1/2" centers
- Non-Intrusive clip sits flush with inside edge of front posts



BACK AND SIDE SWAY BRACES

- Standard for open units only
- 11 gauge back and side sway braces create a rigid structure
- Special triple point brace clip provides a strong rigid anchor point for back sway braces



BACK AND SIDE PANELS

- Standard for closed units only
- Standard stock models include heavy 18 gauge back and side panels for a strong and durable structure
- Multiple panels are used to create full panel height



FOOT PLATES

- Standard stock units include #5025 standard duty foot plates
- Provide a strong and secure anchoring point

5 DAY SHIPPING ON ALL IN-STOCK PRODUCTS

HI-TECH™ H-POST

HALLOWELL® High Capacity Shelving

H-POST OPEN SHELVING HEAVY AND EXTRA HEAVY-DUTY

AVAILABLE IN 7' AND 10' HIGH UNITS



STARTER UNIT



ADDER UNIT



5 SHELF UNIT



6 SHELF UNIT



8 SHELF UNIT

W	D	H		5-Shelf Unit Cat No.	6-Shelf Unit Cat No.	8-Shelf Unit Cat No.	Shelf Capacity*
Heavy-Duty							
36	18	87	Starter	H5510-1807	H5511-1807	H5513-1807	800
36	18	87	Adder	AH5510-1807	AH5511-1807	AH5513-1807	800
36	24	87	Starter	H5510-2407	H5511-2407	H5513-2407	800
36	24	87	Adder	AH5510-2407	AH5511-2407	AH5513-2407	800
36	18	123	Starter	H5510-1810	H5511-1810	H5513-1810	800
36	18	123	Adder	AH5510-1810	AH5511-1810	AH5513-1810	800
36	24	123	Starter	H5510-2410	H5511-2410	H5513-2410	800
36	24	123	Adder	AH5510-2410	AH5511-2410	AH5513-2410	800
48	18	87	Starter	H5710-1807	H5711-1807	H5713-1807	450
48	18	87	Adder	AH5710-1807	AH5711-1807	AH5713-1807	450
48	24	87	Starter	H5710-2407	H5711-2407	H5713-2407	500
48	24	87	Adder	AH5710-2407	AH5711-2407	AH5713-2407	500
48	18	123	Starter	H5710-1810	H5711-1810	H5713-1810	450
48	18	123	Adder	AH5710-1810	AH5711-1810	AH5713-1810	450
48	24	123	Starter	H5710-2410	H5711-2410	H5713-2410	500
48	24	123	Adder	AH5710-2410	AH5711-2410	AH5713-2410	500
Extra Heavy-Duty							
36	18	87	Starter	H7510-1807	H7511-1807	H7513-1807	1200
36	18	87	Adder	AH7510-1807	AH7511-1807	AH7513-1807	1200
36	24	87	Starter	H7510-2407	H7511-2407	H7513-2407	1250
36	24	87	Adder	AH7510-2407	AH7511-2407	AH7513-2407	1250
36	18	123	Starter	H7510-1810	H7511-1810	H7513-1810	1200
36	18	123	Adder	AH7510-1810	AH7511-1810	AH7513-1810	1200
36	24	123	Starter	H7510-2410	H7511-2410	H7513-2410	1250
36	24	123	Adder	AH7510-2410	AH7511-2410	AH7513-2410	1250
48	18	87	Starter	H7710-1807	H7711-1807	H7713-1807	900
48	18	87	Adder	AH7710-1807	AH7711-1807	AH7713-1807	900
48	24	87	Starter	H7710-2407	H7711-2407	H7713-2407	900
48	24	87	Adder	AH7710-2407	AH7711-2407	AH7713-2407	900
48	18	123	Starter	H7710-1810	H7711-1810	H7713-1810	1200
48	18	123	Adder	AH7710-1810	AH7711-1810	AH7713-1810	1200
48	24	123	Starter	H7710-2410	H7711-2410	H7713-2410	1250
48	24	123	Adder	AH7710-2410	AH7711-2410	AH7713-2410	1250
Additional Shelves				Heavy-Duty Cat No.	Extra Heavy-Duty Cat No.		
36	18			5138-3618PL	5139-3618PL	See Above	
36	24			5138-3624PL	5139-3624PL	See Above	
48	18			5138-4818PL	5139-4818PL	See Above	
48	24			5138-4824PL	5139-4824PL	See Above	

* Shelf capacity based on a factor of 1.65

Color: All posts, side sway braces, side panels are 707 Marine Blue.
All shelves, back sway braces, back panels are 711 Platinum

OPEN UNITS: Starter units include four posts, one back sway brace assembly, two side sway brace assemblies, foot plates and 5-8 shelves.
Adder units include two posts, one back sway brace assembly, one side sway brace assembly, foot plates and 5-8 shelves.

H-POST CLOSED SHELVING HEAVY AND EXTRA HEAVY-DUTY



HI-TECH™ H-POST SHELVING

AVAILABLE IN 7' AND 10' HIGH UNITS

W	D	H		5-Shelf Unit Cat No.	6-Shelf Unit Cat No.	8-Shelf Unit Cat No.	Shelf Capacity*
Heavy-Duty							
36	18	87	Starter	H5520-1807	H5521-1807	H5523-1807	800
36	18	87	Adder	AH5520-1807	AH5521-1807	AH5523-1807	800
36	24	87	Starter	H5520-2407	H5521-2407	H5523-2407	800
36	24	87	Adder	AH5520-2407	AH5521-2407	AH5523-2407	800
36	18	123	Starter	H5520-1810	H5521-1810	H5523-1810	800
36	18	123	Adder	AH5520-1810	AH5521-1810	AH5523-1810	800
36	24	123	Starter	H5520-2410	H5521-2410	H5523-2410	800
36	24	123	Adder	AH5520-2410	AH5521-2410	AH5523-2410	800
48	18	87	Starter	H5720-1807	H5721-1807	H5723-1807	450
48	18	87	Adder	AH5720-1807	AH5721-1807	AH5723-1807	450
48	24	87	Starter	H5720-2407	H5721-2407	H5723-2407	500
48	24	87	Adder	AH5720-2407	AH5721-2407	AH5723-2407	500
48	18	123	Starter	H5720-1810	H5721-1810	H5723-1810	450
48	18	123	Adder	AH5720-1810	AH5721-1810	AH5723-1810	450
48	24	123	Starter	H5720-2410	H5721-2410	H5723-2410	500
48	24	123	Adder	AH5720-2410	AH5721-2410	AH5723-2410	500
Extra Heavy-Duty Duty							
36	18	87	Starter	H7520-1807	H7521-1807	H7523-1807	1200
36	18	87	Adder	AH7520-1807	AH7521-1807	AH7523-1807	1200
36	24	87	Starter	H7520-2407	H7521-2407	H7523-2407	1250
36	24	87	Adder	AH7520-2407	AH7521-2407	AH7523-2407	1250
36	18	123	Starter	H7520-1810	H7521-1810	H7523-1810	1200
36	18	123	Adder	AH7520-1810	AH7521-1810	AH7523-1810	1200
36	24	123	Starter	H7520-2410	H7521-2410	H7523-2410	1250
36	24	123	Adder	AH7520-2410	AH7521-2410	AH7523-2410	1250
48	18	87	Starter	H7720-1807	H7721-1807	H7723-1807	900
48	18	87	Adder	AH7720-1807	AH7721-1807	AH7723-1807	900
48	24	87	Starter	H7720-2407	H7721-2407	H7723-2407	900
48	24	87	Adder	AH7720-2407	AH7721-2407	AH7723-2407	900
48	18	123	Starter	H7720-1810	H7721-1810	H7723-1810	1200
48	18	123	Adder	AH7720-1810	AH7721-1810	AH7723-1810	1200
48	24	123	Starter	H7720-2410	H7721-2410	H7723-2410	1250
48	24	123	Adder	AH7720-2410	AH7721-2410	AH7723-2410	1250
Additional Shelves				Heavy-Duty Cat No.	Extra Heavy-Duty Cat No.		
36	18			5138-3618PL	5139-3618PL	See Above	
36	24			5138-3624PL	5139-3624PL	See Above	
48	18			5138-4818PL	5139-4818PL	See Above	
48	24			5138-4824PL	5139-4824PL	See Above	

* Shelf capacity based on a factor of 1.65

Color: All posts, side sway braces, side panels are 707 Marine Blue.
All shelves, back sway braces, back panels are 711 Platinum

CLOSED UNITS: Starter units include four posts, one back panel assembly, two side panel assemblies, foot plates and 5-8 shelves.
Adder units include two posts, one back panel assembly, one side panel assembly, foot plates and 5-8 shelves.



STARTER UNIT



ADDER UNIT



5 SHELF UNIT



6 SHELF UNIT



8 SHELF UNIT

SYSTEM LAYOUT INFORMATION

Standard Shelving with Hi-Tech Shelves

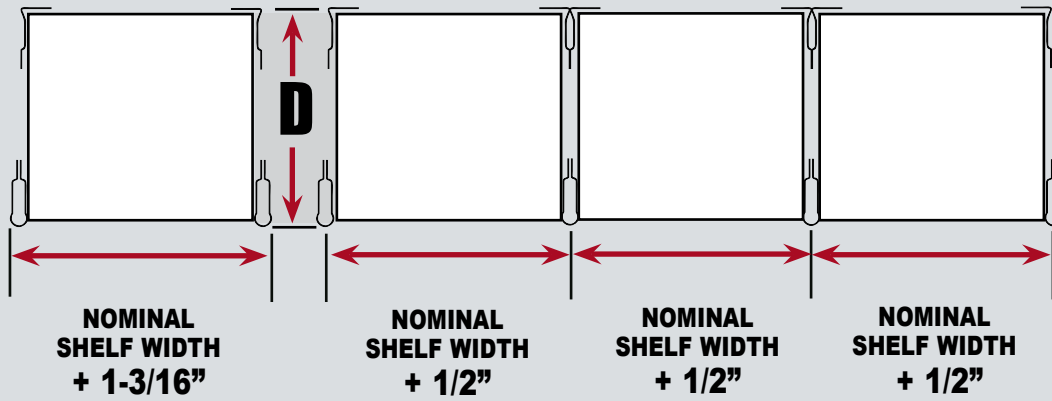

PLUS ADD 3/4" PER ROW

FOR "D" - *SINGLE FACE* ADD 3/16" TO NOMINAL SHELF DEPTH
 FOR "D" - *DOUBLE FACE* ADD 3/8" TO NOMINAL SHELF DEPTH

H-Post Shelving with Hi-Tech Shelves

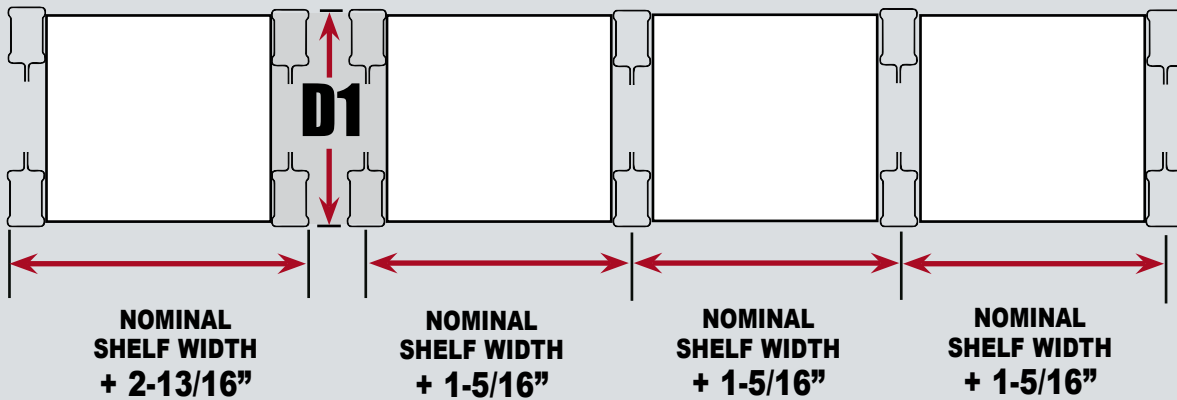

PLUS ADD 1-1/2" PER ROW

FOR "D1" - *SINGLE FACE* ADD 5/16" TO NOMINAL SHELF DEPTH
 FOR "D1" - *DOUBLE FACE* CLOSED MODELS ADD 13/16" TO NOMINAL SHELF DEPTH
 FOR "D1" - *DOUBLE FACE* OPEN MODELS ADD 29/32" TO NOMINAL SELF DEPTH
 NOTE: SHELF WIDTH IS 5/16" UNDER NOMINAL

NOTE: Width of posts should be added to the nominal shelf width in any floor plan to determine the overall shelving width.
 Check "D" and "D1" dimensions for depth/creepage.

UNIT LOAD CAPACITY INFORMATION - 1.65 SAFETY FACTOR

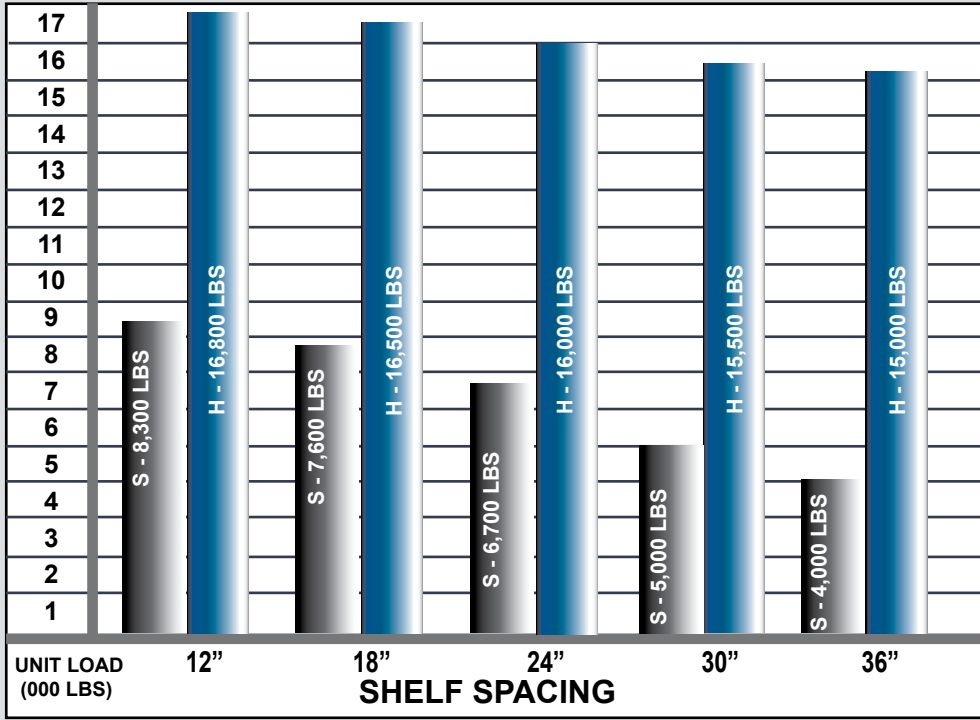

Before selecting type of post, consideration should be given to loads to be carried. Use the formula below to get unit load, then select post type from table.

$$(B-2) \times A = \text{Unit Load}$$

A=Shelf Load (See note 2)
B=Shelves per unit (includes top and bottom shelves)

- WARNING:**
Use H-Posts for:
- High-rise applications
 - Pass-through applications regardless of load
 - High-density, multi-level applications



TYPICAL SWAY BRACE INSTALLATIONS FOR SEISMIC ZONE NO. 0 & 1

Standard Shelving (Beaded Front Posts)
High-Density Shelving (H-Posts)

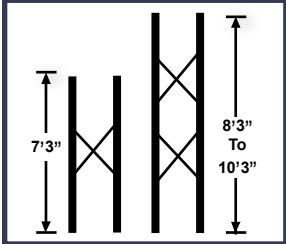

Use of Side Sway Braces
(Part No. 5344 – Standard Shelving)
(Part No. 5341–High-Density Shelving)

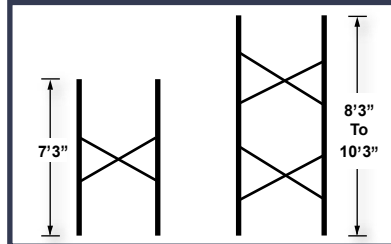

Use of Back Sway Braces (Part No. 5342)
for both standard and high density shelving



NOTES: 1-When splicing posts for increased heights or for multi-level shelving, use the proper number of braces required for the height of the posts being added.
Example: a 10'-3" model increased another 10'-3" in height would require 4 sets of side sway braces and 4 sets of back braces.
2-For additional bracing requirements in Seismic Zones No. 2, 3 and 4, consult the Hallowell Applications Engineering Department.

STOCK → PROGRAM

Quick Ship

THE FASTEST SHIPPING IN THE INDUSTRY...

HEAVY-DUTY INDUSTRIAL GRADE STEEL SHELVING

NO CROSS BRACES **DURATECH**™ PASS-THRU STEEL SHELVING

DuraTech is Hallowell's newest line of pass-thru steel shelving requiring no cross braces allowing access from all sides while providing the maximum strength, durability and stability needed to handle most industrial applications. DuraTech offers versatility and durability for today's modern facilities.

Our complete line of shelving is designed and engineered to the highest standards.

FEATURES:

- Access from all 4 sides
- Top and bottom firmly attached with steel-grip nuts for superior strength
- Available in 5, 7 and 8 shelf models
- Four Angle Posts are used per section allowing units to be individually located, bolted side-by-side or bolted back-to-back.
- Each intermediate shelf uses four sturdy and compact clips
- Clips key firmly into post slots to hold shelves securely in place
- Provides independent positioning of intermediate shelves on 1-1/2" centers
- Bottom shelf is positioned to prevent debris from collecting beneath unit

OUR UNIQUE GRIP NUT DESIGN CREATES A VERY STRONG AND RIGID STRUCTURE

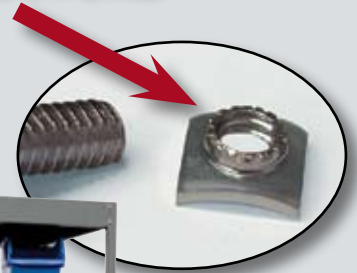

360° ACCESS CREATES A MORE EFFICIENT STORAGE SYSTEM!

COLOR
SELECTION

HALLOWELL GRAY
(HG)

STOCK PROGRAM

Quick Ship

HEAVY-DUTY INDUSTRIAL GRADE STEEL SHELVING

THE FASTEST SHIPPING IN THE INDUSTRY...

Pass-thru Steel Shelving requires **NO CROSS BRACES**

Unique design creates a very strong unit!



Fixed Top Shelf for maximum strength using a bolt and grip nut

Fully adjustable intermediate shelves adds versatility

Fixed bottom shelf adds more rigidity, provides closed base

4 bolts at each corner top and bottom provide a very strong frame for maximum strength

All Units Include: Four angle posts, two DuraTech bolt-in shelves to be used at unit top and bottom and intermediate adjustable shelves with shelf clips applicable to unit ordered. All DuraTech shelving units are free standing and can be joined end-to-end or back-to-back.

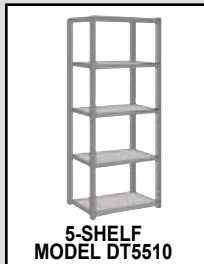

5 SHELF - 36" WIDE X 7'-3" HIGH UNITS 3-ADJUSTABLE SHELVES				
Model #	W	D	H	Capacity Per Shelf
DT5510-12	36"	12"	7'3"	800
DT5510-18	36"	18"	7'3"	800
DT5510-24	36"	24"	7'3"	800

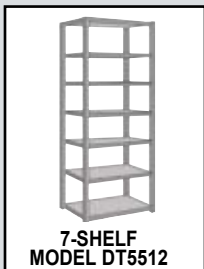

7 SHELF - 36" WIDE X 7'-3" HIGH UNITS 5-ADJUSTABLE SHELVES				
Model #	W	D	H	Capacity Per Shelf
DT5512-12	36"	12"	7'3"	800
DT5512-18	36"	18"	7'3"	800
DT5512-24	36"	24"	7'3"	800



8 SHELF - 36" WIDE X 7'-3" HIGH UNITS 6-ADJUSTABLE SHELVES				
Model #	W	D	H	Capacity Per Shelf
DT5513-12	36"	12"	7'3"	800
DT5513-18	36"	18"	7'3"	800
DT5513-24	36"	24"	7'3"	800

**ONE-TIME INVESTMENT,
LIFETIME OF USE!**

Hallowell
www.Hallowell-List.com

DURATECH™ PASS-THRU STEEL SHELVING

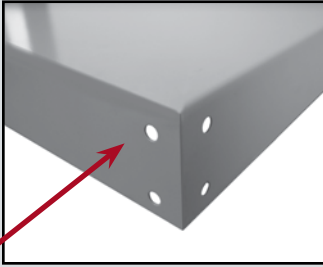

Top and bottom shelves attach with bolts at each corner providing a strong and rigid structure



Bottom shelf is positioned to prevent debris from collecting beneath unit



Top and bottom firmly attached with steel-grip nuts for superior strength



Compression Shelf Clip for intermediate shelves



5-SHELF
MODEL DT5710

5 SHELF - 48" WIDE X 7'-3" HIGH UNITS 3-ADJUSTABLE SHELVES				
Model #	W	D	H	Capacity Per Shelf
DT5710-12	48"	12"	7'3"	400
DT5710-18	48"	18"	7'3"	450
DT5710-24	48"	24"	7'3"	500



7-SHELF
MODEL DT5712

7 SHELF - 48" WIDE X 7'-3" HIGH UNITS 5-ADJUSTABLE SHELVES				
Model #	W	D	H	Capacity Per Shelf
DT5712-12	48"	12"	7'3"	400
DT5712-18	48"	18"	7'3"	450
DT5712-24	48"	24"	7'3"	500



8-SHELF
MODEL DT5713

8 SHELF - 48" WIDE X 7'-3" HIGH UNITS 6-ADJUSTABLE SHELVES				
Model #	W	D	H	Capacity Per Shelf
DT5713-12	48"	12"	7'3"	400
DT5713-18	48"	18"	7'3"	450
DT5713-24	48"	24"	7'3"	500

DURATECH ANGLE POSTS

- Roll formed into a unique angle shape for maximum strength
- The long leg is punched on 1-1/2" centers to allow independent shelf adjustment
- Four Angle Posts are used per section allowing units to be individually located, bolted side-by-side or bolted back-to-back.



DURATECH ONE PIECE SHELF CLIP

- Each intermediate shelf requires four sturdy and compact clips
- Clips key snugly into post slots to hold shelves securely in place
- Provides independent positioning of intermediate shelves on 1-1/2" centers



DURATECH HEAVY DUTY INTERMEDIATE SHELVES

- Tubular flange front and rear for greater strength
- Exclusive triple bend side flanges for added strength
- Lapped and welded corners
- Available in three load capacity classes up to 48" wide spans and 36" depths
- Top of shelf is punched to accept shelf dividers
- Uses four one piece shelf clips per shelf



DURATECH TOP/BOTTOM SHELVES

- Triple flanged at all four sides for maximum rigidity, durability and stability
- Bottom shelf is positioned to close space to floor preventing debris from collecting beneath
- Bolted to angle posts at all four corners using special bolts and steel-grip nuts preventing unit sway without the use of intrusive sway bracing for complete 4-sided access



All units shown include Hallowell heavy-duty intermediate shelves. Medium-Duty and Extra Heavy-Duty units are also available.

5 DAY SHIPPING ON ALL IN-STOCK PRODUCTS

HALLOWELL GUARDRAIL

Hallowell guardrail is designed, engineered, and manufactured to the highest industry standards, using heavy gauge steel, and a unique integrated fastening system. This integrated system incorporates the fastening hardware as part of the column design so there will be no “stripped” out connections. A properly installed and anchored guardrail system is designed to safeguard people, property and facility assets from accidents involving material handling equipment.

Each Hallowell Guardrail system is designed for your specific safety application. It is recommended to use 18” high for impact protection of facility assets including office in-plants, conveyor systems, mezzanines, shelving and racking systems. The use of the 42” double rail system is recommended when protecting and separating pedestrians and personnel from your material handling equipment. These areas include walkways, bathrooms, entry and exit points, electrical panels, break areas, and exposed work stations.

Guardrail components have an industry approved, safety-yellow powdercoated finish. All guardrail sections are shipped with the required fasteners and other necessary hardware to properly install and anchor into your concrete floor.



Description	Nom. Length (ft.)	Height (in.)	Weight (lbs.)	Catalog Number
Rail	3		22	GR-03
Rail	4		26	GR-04
Rail	5		35	GR-05
Rail	6		41	GR-06
Rail	7		46	GR-07
Rail	8		53	GR-08
Rail	10		65	GR-10
Post		18	33	GRPA18-1
Post		42	51	GRPA42-2
Lift-out rail Adapter (pair)			12	LOA



HALLOWELL POST PROTECTORS

Designed to protect your investment, Hallowell Post Protectors are fabricated of extra heavy-duty steel and are available in three heights to meet your specific requirements. Anchor plates are 1/4" steel that is welded to 3/8" formed steel uprights and finished in a bright safety-yellow powder coat.



Description	Height	Catalog No.
Post Protector	12"	PP070712SY
Post Protector	18"	PP070718SY
Post Protector	24"	PP070724SY

STOCK PROGRAM

Quick Ship

THE FASTEST SHIPPING IN THE INDUSTRY...



**FUNCTIONAL
DURABLE
ADAPTABLE**

800 SERIES Heavy-Gauge KD Cabinets

Provides maximum protection to tools, dies, delicate instruments, supplies, and personal belongings. Neat and attractive in appearance. Designed to meet government requirements.

FEATURES:

- Cabinet is fabricated from heavy gauge steel for appearance and durability.
- All metal parts are precision engineered. No bolt heads show in front or on side panels.
- Positive three-point locking (top, center and bottom) and theft resistant hinges for security.
- Chrome-plated locking handle has built-in grooved key cylinder lock.
- Shelves easily adjust up or down in 2" increments. Triple flanged front for added strength (300 lb. capacity).
- Doors swing out quietly a full 180° and are "HAT" section reinforced.
- Corner Foot Gussets provide added rigidity and stability



STORAGE Model 815
Shown in Platinum



WARDROBE Model 835
Shown in Parchment



COMBINATION Model 855
Shown in Midnight Ebony

Reinforced Doors

All-welded door frame assembly



Width	Depth	Height	Knock-Down Cat. No.	Fully-Assembled Cat No.	Color Selection
Storage Cabinets					
36	18	78	815-S-18	815-S-18A	PT, ME, PL-AM
36	24	78	815-S-24	815-S-24A	PT, ME, PL-AM
Wardrobe Cabinets					
36	18	78	835-W-18	835-W-18A	PT, ME, PL-AM
36	24	78	835-W-24	835-W-24A	PT, ME, PL-AM
Combination Cabinets					
36	18	78	855-C-18	855-C-18A	PT, ME, PL-AM
36	24	78	855-C-24	855-C-24A	PT, ME, PL-AM
Storage Cabinet Conversion Kit					
36	18		S-3618	-----	PT, ME, PL-AM
36	24		S-3624	-----	PT, ME, PL-AM
Wardrobe Cabinet Conversion Kit					
36			W-36		
Combination Cabinet Conversion Kit					
36	18		C-3618		PT, ME, PL-AM
36	24		C-3624		PT, ME, PL-AM

(Includes 1 center partition and 3 half width shelves, 1 half width coat rod)

COLOR SELECTION

729 PARCHMENT (PT)

708 MIDNIGHT EBONY (ME)

711 ANTIMICROBIAL PLATINUM (PL-AM)

Order your cabinets in our specially formulated Antimicrobial powder coat finish that protects against bacteria, mold, yeast & mildew for up to 20 years!

**ALL-WELDED
HEAVY-DUTY
CORROSION RESISTANT**



Hallowell
www.Hallowell-List.com

MAXVIEW™ CORROSION RESISTANT CABINETS

HIGH VISIBILITY All-Welded Cabinets

Taking the MaxView Locker to the next level by incorporating high security 3-point turn-handle latch and adjustable shelves.



FEATURES:

BODY CONSTRUCTION: All-welded 16 gauge heavy-duty tubular frame construction from galvanized sheet steel, sides and back are 1/2" 13 gauge flattened expanded metal. Top and bottom are heavy-duty galvanized corrosion resistant sheet steel, fully-assembled

BODY STYLES: Single tier

DOOR: 14 gauge door is diamond perforated for maximum visibility and ventilation. Includes a welded-in full height door stiffener

HINGES: Heavy-duty 13 gauge 7-knuckle (3 hinges per door)

HANDLE: Cremone 3-point high-security turn handle latching with heavy-duty 3/8 lock rods which engage the top and bottom locker frames while the cam engages the frame at the door jamb near the handle.

SHELVES: Four 16 gauge sheet steel welded-in fixed shelves are fabricated from galvanized corrosion resistant sheet steel. Adjustable on 1" centers.



Heavy gauge tubular frame. Bottom shelf of locker sits a full 2-3/4" above finished floor protecting locker contents from water damage.



Width	Depth	Opening Height	Frame Height	Tier	Grouping	Openings Per Group	Fully-Assembled Cat No.	Color Selection
ONE TIER								
24-3/4	22	72	74-3/4	1	1-wide	1	HMVT422-1SS	SS



5 DAY SHIPPING ON ALL IN-STOCK PRODUCTS

STOCK → PROGRAM

Quick Ship



FOR REALLY TOUGH INDUSTRIAL APPLICATIONS

THE FASTEST SHIPPING IN THE INDUSTRY...

DURATOUGH™

Classic and Galvanite™ Series All-Welded Cabinets

Classic Series cabinets are fabricated from prime grade cold rolled sheet steel.

Galvanite Series cabinets are fabricated from galvanized sheet steel which has a zinc-iron alloy coating that is applied at the mill providing protection against high-humidity and moist environments. This coating also prevents corrosion from spreading when the paint and/or coating is scratched away.

Heavy-Duty cabinets are fabricated from 16 gauge sheet steel and are fully-welded creating a rigid, durable unit.

Extra Heavy-Duty cabinets are fabricated from 14 gauge steel which is 25% thicker than 16 gauge providing MAXIMUM durability.

Safety-View® Series cabinets incorporate polycarbonate panels in both doors of our extra heavy-duty Classic Series cabinets allowing contents to be visible without compromising security.

Ventilated Series cabinets are fabricated to the same rugged standards as our extra heavy-duty Classic Series cabinets with the added benefit of being fully ventilated with diamond perforated doors and sides and a 13 gauge flattened expanded metal back.



Combination Cabinet



Storage Cabinet



Safety-View Cabinet



Ventilated Cabinet

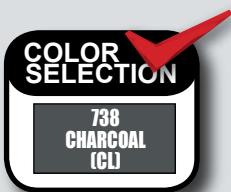

CLASSIC & GAVANITE SERIES Steel Cabinets

Hallowell

www.Hallowell-List.com

DURATOUGH™ ALL-WELDED CABINETS



CORROSION RESISTANT

DuraTough™ Classic Series

Catalog Number	Type	Width (In)	Depth (In)	Height (In)	No. of Shelves
HEAVY-DUTY-16 GAUGE					
HW6SC6142-2CL	Storage	36	21	42	2
HW6SC6160-3CL	Storage	36	21	60	3
HW6SC6178-4CL	Storage	36	21	78	4
HW6SC6478-4CL	Storage	36	24	78	4
HW6SC8460-3CL	Storage	48	24	60	3
HW6SC8478-4CL	Storage	48	24	78	4
HW6SC0478-4CL	Storage	60	24	78	4
HW6CC6478-4CL	Combination	36	24	78	4
HW6CC8478-4CL	Combination	48	24	78	4
HW6CC0478-4CL	Combination	60	24	78	4
ADDITIONAL SHELVES, HEAVY-DUTY-16 GAUGE					
HW6SCS61CL	Shelf	36	21	----	1
HW6SCS64CL	Shelf	36	24	----	1
HW6SCS84CL	Shelf	48	24	----	1
EXTRA HEAVY-DUTY-14 GAUGE					
HW4SC6142-2CL	Storage	36	21	42	2
HW4SC6160-3CL	Storage	36	21	60	3
HW4SC6178-4CL	Storage	36	21	78	4
HW4SC6478-4CL	Storage	36	24	78	4
HW4SC8460-3CL	Storage	48	24	60	3
HW4SC8478-4CL	Storage	48	24	78	4
HW4SC0478-4CL	Storage	60	24	78	4
HW4CC6478-4CL	Combination	36	24	78	4
HW4CC8478-4CL	Combination	48	24	78	4
HW4CC0478-4CL	Combination	60	24	78	4
ADDITIONAL SHELVES, EXTRA HEAVY-DUTY-14 GAUGE					
HW4SCS61CL	Shelf	36	21	----	1
HW4SCS64CL	Shelf	36	24	----	1
HW4SCS84CL	Shelf	48	24	----	1

DuraTough™ Galvanite Series

Catalog Number	Type	Width (In)	Depth (In)	Height (In)	No. of Shelves
HEAVY-DUTY-16 GAUGE					
HWG6SC6142-2CL	Storage	36	21	42	2
HWG6SC6160-3CL	Storage	36	21	60	3
HWG6SC6178-4CL	Storage	36	21	78	4
HWG6SC6478-4CL	Storage	36	24	78	4
HWG6SC8460-3CL	Storage	48	24	60	3
HWG6SC8478-4CL	Storage	48	24	78	4
HWG6SC0478-4CL	Storage	60	24	78	4
HWG6CC6478-4CL	Combination	36	24	78	4
HWG6CC8478-4CL	Combination	48	24	78	4
HWG6CC0478-4CL	Combination	60	24	78	4
ADDITIONAL SHELVES, HEAVY-DUTY-16 GAUGE					
HWG6SCS61CL	Shelf	36	21	----	1
HWG6SCS64CL	Shelf	36	24	----	1
HWG6SCS84CL	Shelf	48	24	----	1
EXTRA HEAVY-DUTY-14 GAUGE					
HWG4SC6142-2CL	Storage	36	21	42	2
HWG4SC6160-3CL	Storage	36	21	60	3
HWG4SC6178-4CL	Storage	36	21	78	4
HWG4SC6478-4CL	Storage	36	24	78	4
HWG4SC8460-3CL	Storage	48	24	60	3
HWG4SC8478-4CL	Storage	48	24	78	4
HWG4SC0478-4CL	Storage	60	24	78	4
HWG4CC6478-4CL	Combination	36	24	78	4
HWG4CC8478-4CL	Combination	48	24	78	4
HWG4CC0478-4CL	Combination	60	24	78	4
ADDITIONAL SHELVES, EXTRA HEAVY-DUTY-14 GAUGE					
HWG4SCS61CL	Shelf	36	21	----	1
HWG4SCS64CL	Shelf	36	24	----	1
HWG4SCS84CL	Shelf	48	24	----	1

DuraTough™ Safety-View®

Catalog Number	Type	Width (In)	Depth (In)	Height (In)	No. of Shelves
HW4SVSC6478-4CL	Storage	36	24	78	4
HW4SVSC8478-4CL	Storage	48	24	78	4

DuraTough™ Ventilated

Catalog Number	Type	Width (In)	Depth (In)	Height (In)	No. of Shelves
HW4VSC6478-4CL	Storage	36	24	78	4
HW4VSC8478-4CL	Storage	48	24	78	4

5 DAY SHIPPING ON ALL IN-STOCK PRODUCTS

STOCK → **PROGRAM**

Quick Ship

THE FASTEST SHIPPING IN THE INDUSTRY...

DuraTough™ Cabinet Leg Kits

Catalog Number	Type	Width (In)	Depth (In)	Height (In)	Legs Per Kit
HWC4LK-1G-HG	Leg Kit	4	21	4	2
HWC4LK-4G-HG	Leg Kit	4	24	4	2

Leg kits can be added to any Hallowell DuraTough Cabinet. Legs are fabricated from galvanized corrosion resistant steel and are easily bolted to cabinet bottom. Includes hardware for field attachment.



DuraTough™ Cabinet Drawers

Catalog Number	Type	Width (In)	Depth (In)	Drawer Height
FKSCD36-2CL	2 Drawer	36	24	7.5
FKSCD48-2CL	2 Drawer	48	24	7.5
FKSCD36-3CL	3 Drawer	36	24	5
FKSCD48-3CL	3 Drawer	48	24	5

Note: Drawer units should always be installed into the lower portion of the cabinets to insure stability when opening the drawers. *Only one drawer should be opened at a time.*



18-gauge full-height door stiffener provides maximum rigidity to both doors



Heavy-Duty 3/16" thick steel handle with padlock hasp.



1/8" thick latch and 3/8" diameter lock rods insure maximum security

Standard Features for all DuraTough™ Classic and Galvanite™ Series Cabinets

- All-welded construction
- Double door design
- Solid doors are reinforced with an 18 gauge full-height door stiffener providing a rigid torque-free door.
- 3-point turn handle locking using 3/8" diameter locking rods operated by a 3/16" gauge steel handle. Handle is painted to match cabinet.
- Heavy-duty 13 gauge 7-knuckle 3-1/2" butt hinges welded to door and securely riveted to frame.
 - Solid sides are formed to be integral with vertical door frame.
 - Top is formed to be integral with horizontal top door frame.
 - Bottom is formed to be integral with horizontal bottom door frame and includes double return bends at all four sides maximizing unit rigidity.

- Back is welded to cabinet top, bottom and sides
- Shelves are formed to provide maximum capacity and are adjustable on 3" centers. Shelves bolt to shelf support channels which are welded to sides.
 - 78" high storage cabinets include 4-adjustable shelves
 - 60" high storage cabinets include 3-adjustable shelves
 - 42" high storage cabinets include 2-adjustable shelves
 - 78" high combination cabinets include one full-width upper shelf, a center partition, 3 partial-width shelves and one partial-width coat rod
- Optional leg kits are available and can be bolted on to all DuraTough cabinets.
- Color: 738 Charcoal

PRACTICAL, COMPACT AND DURABLE WORKBENCHES

Hallowell
www.Hallowell-List.com

WORKBENCHES

1-3/4" WORK SURFACES



STEEL TOP

Heavy 12 gauge steel with no holes on the work surface withstands hard shop use for years. Will not crack, splinter, gouge, or absorb oil.



SHOP TOP

Shop Top's layered high-density particleboard offers superior screw holding characteristics. The top and bottom layers are seal to resist conventional spills. The nonconductive, splinter-proof top is 30 percent harder than maple.



LAMINATED HARDWOOD TOP

Thoroughly seasoned, kiln dried hardwood, face-glued to provide an extremely durable, attractive and long lasting work surface.

Work Top Capacity: 200 lbs/sq ft evenly distributed over entire surface.

HEAVY-DUTY ADJUSTABLE LEG WORKBENCHES

Hallowell Workbenches are constructed of only the finest materials and represent the pinnacle in quality, strength, and stability. Our industrial workbenches are designed to withstand the harshest work environments year-in and year-out. With the flexible selection of standard and cost-effective components, these highly efficient units insure maximum productivity in the workplace.

Riser

Provides a 12" high x 10" deep shelf above the work surface

Drawer

24" deep x 18" wide x 6" high. Easily installs under the bench top and can be secured with an optional padlock



Back and End Stops

A 3" high barrier with rounded front corners.

Stringer

Required for lateral stability and acts like a stop for a second bottom shelf.

Lower shelf

Full width 11-3/16" deep.

Adjustable Legs

Width (in.)	Depth (in.)	Height (in.)	Top	Catalog No.	Color
Workbenches (includes legs, top and stringer)					
48	30	34	Shop Top	HWB4830E-ME	ME
60	30	34	Shop Top	HWB6030E-ME	ME
72	30	34	Shop Top	HWB7230E-ME	ME
72	36	34	Shop Top	HWB7236E-ME	ME
48	30	34	Laminated Hardwood	HWB4830M-ME	ME
60	30	34	Laminated Hardwood	HWB6030M-ME	ME
72	30	34	Laminated Hardwood	HWB7230M-ME	ME
72	36	34	Laminated Hardwood	HWB7236M-ME	ME
48	30	34	12 gauge Steel	HWB4830S-ME	ME
60	30	34	12 gauge Steel	HWB6030S-ME	ME
72	30	34	12 gauge Steel	HWB7230S-ME	ME
72	36	34	12 gauge Steel	HWB7236S-ME	ME

Width (in.)	Depth (in.)	Height (in.)	Item	Catalog No.	Color
Workbenches Add-on Accessories					
18	24	6	Drawer	HWB-BD-60-ME	ME
48	30	6	Back & End Stop Kit	HWB-BES-4830-ME	ME
60	30	6	Back & End Stop Kit	HWB-BES-6030-ME	ME
72	30	6	Back & End Stop Kit	HWB-BES-7230-ME	ME
72	36	6	Back & End Stop Kit	HWB-BES-7236-ME	ME
48	10	12	Riser	HWB-BR-48-ME	ME
60	10	12	Riser	HWB-BR-60-ME	ME
72	10	12	Riser	HWB-BR-72-ME	ME
48	12		Lower Shelf	HWB-LS-48-ME	ME
60	12		Lower Shelf	HWB-LS-60-ME	ME
72	12		Lower Shelf	HWB-LS-72-ME	ME
		24	Leg Extension	HWB-LE-24-ME	ME

5 DAY SHIPPING ON ALL IN-STOCK PRODUCTS

45

STOCK → PROGRAM

Quick Ship



THE FASTEST SHIPPING IN THE INDUSTRY...

FORT KNOX WORKBENCHES

FORT KNOX



Modular Utility Storage and Workbench System

By combining our adjustable Rivetwell Shelving, Heavy-Duty All-Welded Cabinets, Workbenches and Locker/Drawer units we created a uniquely functional, yet durable modular system providing numerous components to allow you to custom design your perfect workspace.

Fabricated from heavy gauge steel and coated with a unique textured two-tone powder coat finish, the Fort Knox system will stand up to the most demanding users. Our intelligent design allows each major component to be utilized stand alone or in conjunction with any of the other major components.



UNIQUE GOLF LOCKER
for storing
golf bags and
all related
accessories



The Perfect Workspace Solution

A WORK AND STORAGE SYSTEM THAT ALLOWS YOU TO CUSTOM DESIGN YOUR OWN WORKPLACE



	Unit Width	Unit Depth	Unit Height	Catalog No.
Cabinets - Includes 4 full width shelves				
	36	24	78	FKSC6478-4BR-HT
	48	24	78	FKSC8478-4BR-HT
Cabinet Drawer Kits				
2-Drawer	36	24	15	FKSCD36-2RR-HT
	48	24	15	FKSCD48-2RR-HT
3-Drawer	36	24	15	FKSCD36-3RR-HT
	48	24	15	FKSCD48-3RR-HT
Workbench Pedestals				
3-Drawer	18	24	32	FKWP8432-3D-BR-HT
	24	24	32	FKWP4432-3D-BR-HT
6-Drawer	18	24	32	FKWP8432-6D-BR-HT
	24	24	32	FKWP4432-6D-BR-HT
Double-Door	18	24	32	FKWP8432-1BR-HT
	24	24	32	FKWP4432-1BR-HT
Workbench Tops				
Shop Top	60	24	1-3/4	FKWT6024E
	72	24	1-3/4	FKWT7224E
Laminated Hardwood	60	24	1-3/4	FKWT6024M
	72	24	1-3/4	FKWT7224M
Steel	60	24	1-3/4	FKWT6024S
	72	24	1-3/4	FKWT7224S
Lower Pedestal Shelf				
	24	8	1	FKWPS24ME-HT
	30	8	1	FKWPS30ME-HT
	36	8	1	FKWPS36ME-HT
Side & Back Rail Kits				
	60	24	4	FKSBRK6024RR-HT
	72	24	4	FKSBRK7224RR-HT
Workbench Power Strips				
3-Outlets	60	3		FKWEP60-3ME-HT
4-Outlets	72	3		FKWEP72-4ME-HT
Light Kit				
	22	3	6	FKWLK22
Pegboard Kits Each Kit Includes (2) pcs				
	22	3/4	44-1/4	FKWBP22RR-HT
	30	3/4	44-1/4	FKWBP60RR-HT
	36	3/4	44-1/4	FKWBP72RR-HT
Pegboard Shelves				
	20	5	1	FKWS22ME-HT
	28	5	1	FKWS30ME-HT
	34	5	1	FKWS36ME-HT
Lockers				
Single Door Locker	18	24	78	FKL8478-1BR-HT
	24	24	78	FKL4478-1BR-HT
3-Drawers	18	24	78	FKL8478-3D-BR-HT
	24	24	78	FKL4478-3D-BR-HT
6-Drawers	18	24	78	FKL8478-6D-BR-HT
	24	24	78	FKL4478-6D-BR-HT
Golf Club Locker	18	24	78	FKL8478-1GL-BR-HT
Shelving Units				
with Particle Board Decking	36	24	78	FKR362478-5S-W-BR-HT
	8	24	78	FKR482478-5S-W-BR-HT
with EZ-Deck Steel Decking	36	24	78	FKR362478-5S-E-BR-HT
	48	24	78	FKR482478-5S-E-BR-HT
with Featherdeck Decking	36	24	78	FKR362478-5S-F-BR-HT
	48	24	78	FKR482478-5S-F-BR-HT
Extra Shelf Level				
with Particle Board Decking	36	24	3-1/2	FKRL3624W-RR-HT
	48	24	3-1/2	FKRL4824W-RR-HT
with EZ-Deck Steel Decking	36	24	3-1/2	FKRL3624E-RR-HT
	48	24	3-1/2	FKRL4824E-RR-HT
with Featherdeck Decking	36	24	3-1/2	FKRL3624F-RR-HT
	48	24	3-1/2	FKRL4824F-RR-HT

STOCK → **PROGRAM**

Quick Ship

FORT KNOX MODULAR SYSTEM COMPONENTS & FEATURES

THE FASTEST SHIPPING IN THE INDUSTRY...

FORT KNOX SHELVING



Versatile quick assembly Rivetwell shelving provides heavy-duty storage while allowing four sided access by eliminating the need for anti-sway bracing. Four-sided beam design provides maximum decking capacity. Each unit includes 5 shelf levels including top and bottom and is available in choice of 36" and 48" wide units. Order additional levels as needed. The unique color combination of black uprights and red beams provides an attractive appearance and allows perfect integration into your custom configured system. We offer three decking choices. Order particle board or EZ-Deck steel decking for maximum capacity. Featherdeck is perfect when a clean, lightweight solution is desired. Featherdeck will stand up to most chemicals and liquids.

FORT KNOX SHELF OPTIONS

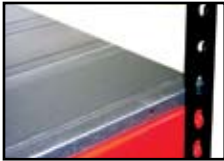

EZ-Deck

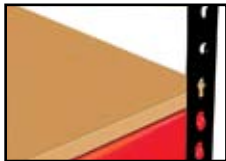

Particle Board

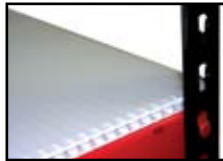

Featherdeck

If additional levels are needed for your setup, shelf levels can be ordered in each of the three available deckings to meet your specific requirements.

FORT KNOX CABINETS



Shown with optional drawer kit

Fabricated of extra heavy-duty 14 gauge steel, reinforced doors and 1,450 lb. capacity adjustable shelves, durability is an understatement. Best-in-class super-duty 13 gauge full height hinge and 3/16" ergonomically engineered cremone turn-handle insure proper door alignment and operation for a lifetime of use. Each cabinet includes 4 full-width shelves.

Doors are secured in the closed position with our high-security 3-point locking system which includes 3/8" diameter round locking rods that are held securely in place by welded-in pry-resistant retainers. These rods engage both the top and bottom of the cabinet door frame when the door is closed which the center latch rotates behind the slave door. Handle includes provisions for a padlock (locks not included).

Shelves are fully adjustable on 3" centers allowing you to maximize the cabinet's interior space. Cabinets are available in 36" and 48" widths and can accommodate our modular cabinet drawer units. With durable textured powder coat finish presented in an attractive two-tone color combining a black body with red door, you can be sure our system will be the highlight of your workspace environment.

FORT KNOX OPTIONAL DRAWER KITS



Choose From 2 or 3 Drawer Inserts

Each modular drawer unit is 15" high and is available in a 2-drawer or 3-drawer version. Drawers allow maximum weight bearing capacity by combining heavy 14 gauge construction with super-strength 500 lb. capacity full-extension glides. The full extension allows full use of each drawer.

Drawer units can be easily added to any Fort Knox and DuraTough All-Welded Cabinet allowing you to custom configure your cabinets to your specific needs.

Note: Drawer units should always be installed into the lower portion of the cabinets to insure stability when opening the drawers. *Only one drawer should be opened at a time.*



FORT KNOX PEDESTAL UNITS



3 Drawer Pedestal



6 Drawer Pedestal



Double Door Pedestal

Perfect as stand-alone units or as supports for workbenches. These versatile all-welded heavy-duty modules are available in multiple sizes and configurations and provide ample storage for tools.

Double Door Workbench Pedestals are perfect for storage of larger items. Our high security 3-point latching system is pad-lockable (locks not included).

Drawer Workbench Pedestals are engineered for years of smooth operation while the ergonomic handles add style. Full-extension drawer glides allow full use of drawer space. Available in both 6-drawer and 3-drawer models.

FORT KNOX WORKBENCH TOPS



Workbench Shop Top



Workbench Laminated Hardwood Top



Workbench Steel Top

Choose from rugged steel, laminated hardwood and composite core resin board workbench tops. Each is 1-3/4" thick and provides a perfect working surface.

FORT KNOX WORKBENCH ACCESSORIES

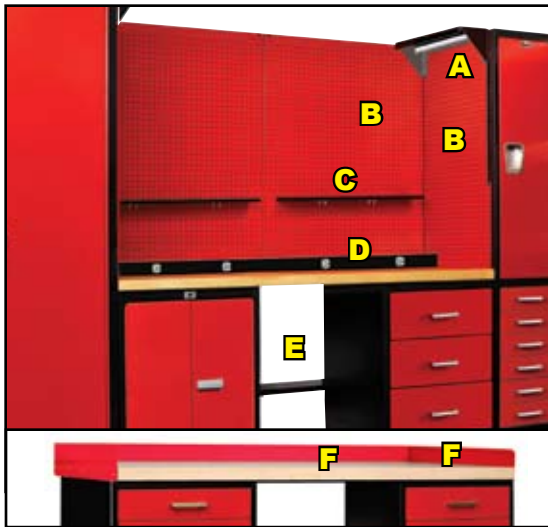

A - LIGHT KITS provide a convenient way to illuminate your work surface. Each light kit easily attaches to our steel pegboards allowing you to mount is where light is needed most.

B - STEEL PEGBOARD PANELS are engineered in three convenient sizes to fit perfectly into our Fort Knox System. Our unique design allows panels to be wall mounted or attached to the sides of our Fort Knox lockers and cabinets. Heavy-gauge design is perfect for industrial applications.

C - PEGBOARD SHELVES mount to the pegboard providing shelf space exactly where you need it. Available in three sizes.

D - ELECTRICAL POWER BAR provides additional power when needed. Available to match both 60" and 72" wide workbenches.

E - LOWER PEDESTAL SHELF mounts between two bench pedestals to provide out of the way storage. Available in three lengths to work with most pedestal configurations.

F - SIDE AND BACK RAIL KITS provide edging to your workbench surface to prevent items from sliding and/or rolling off. Perfect when workbenches and being used stand alone.

FORT KNOX LOCKERS



All-welded heavy-duty Fort Knox lockers are available in multiple sizes and configurations allowing maximum versatility. All doors include a stainless steel recessed handle with padlock hasp (locks not included).

FULL DOOR LOCKERS includes an upper fixed shelf with four adjustable stainless steel shelves.

COMBINATION LOCKERS include three stainless steel adjustable shelves with choice of 3 or 6 lower drawers. Drawers are interchangeable with our pedestal drawer units.

GOLF LOCKERS are engineered specifically for the golfer allowing ample space for your golf bag, clubs, shoes and accessories. Locker doors include ball & tee ventilation. Two adjustable stainless steel shelves are included in addition to one fixed upper shelf.

STOCK  PROGRAM

Quick Ship



**PREMIUM WARDROBE
KD STOCK LOCKERS**

THE FASTEST SHIPPING IN THE INDUSTRY...

Premium all-purpose wardrobe lockers are traditional louvered door lockers designed for storage of all personal belongings

FEATURES:

BODY CONSTRUCTION: Knock-down, 24 gauge

BODY STYLES: Single, double and triple tier

DOOR: 16 gauge louvered for added ventilation

HINGES: Continuous piano type

HANDLE: Stainless steel recessed handle with multi-point gravity lift-type latching for a modern look and added safety. Recessed handle protects finish from being marred by padlock.

HOOKS: One double prong ceiling hook and two single hooks per single and double tier opening. One double prong ceiling hook for triple tier.

COAT RODS: Available for single tier at a nominal cost

SHELVES: Hat shelf is included in single tier lockers.

LEGS: 6" high legs are standard. Lockers without legs are available for a nominal charge.

APPEARANCE: Parchment, Hallowell Gray and Marine Blue lockers include matching body colors. Maroon and Green Mist lockers include Parchment body and sides. Order Finished End Panels for exposed row ends if desired. Finished End Panels install over top of universal side panels adding strength and rigidity at exposed row ends and can be ordered to match locker door/frame color.

GENERAL FEATURES:

- Lockers can be ordered fully-assembled or knock-down for assembly at destination.
- Order 3-wide units for best value. Order 1-wide units to complete quantity needed for each continuous row.
- Lockers can be ordered in combination with Premium box lockers.
- All items shown are available for shipment within 5 business days of receipt of order.
- Aluminum number plates (#1-up) with mounting hardware are included. Number plate face is black with silver etched numerals. If a special numbering sequence is required, please specify when ordering. Number sequence must be consecutive numbers equal to the number of openings (doors) ordered.
- Locks are not included.

With Piano Hinge



Single Tier, 1 wide, 1 opening



Double Tier, 1 wide, 2 openings



Triple Tier, 1 wide, 3 openings



Single Tier, 3 wide, 3 openings



Deep drawn stainless steel recessed handle with gravity lift-type latching for doors 20" high and higher

RUST RESISTANT
GALVANITE SHEET STEEL
 can be ordered
 ON ANY PRODUCTION LOCKER OR CABINET
 AS AN OPTION

When you order the Galvanite Option, Lockers are fabricated from prime galvanized (hot-dipped zinc coated, annealed) sheet steel, then finished with an electrostatically applied high grade powder coat finish providing double protection against corrosion.

PREMIUM WARDROBE KD STOCK LOCKERS

Hallowell

www.Hallowell-List.com

PREMIUM KD STOCK WARDROBE LOCKERS

Width	Depth	Opening Height	Frame Height	Tier	Grouping	Openings Per Group	Knock-Down Cat No.	Fully-Assembled Cat No.	Color Selection
SINGLE TIER									
12	12	60	66	1	1-wide	1	U1226-1	U1226-1A	PT, HG
12	12	60	66	1	3-wide	3	U3226-1	U3226-1A	PT, HG
12	15	60	66	1	1-wide	1	U1256-1	U1256-1A	PT, HG
12	15	60	66	1	3-wide	3	U3256-1	U3256-1A	PT, HG
12	18	60	66	1	1-wide	1	U1286-1	U1286-1A	PT, HG
12	18	60	66	1	3-wide	3	U3286-1	U3286-1A	PT, HG
12	12	72	78	1	1-wide	1	U1228-1	U1228-1A	PT, HG, MB, GM, MN
12	12	72	78	1	3-wide	3	U3228-1	U3228-1A	PT, HG, MB, GM, MN
12	15	72	78	1	1-wide	1	U1258-1	U1258-1A	PT, HG, MB, GM, MN
12	15	72	78	1	3-wide	3	U3258-1	U3258-1A	PT, HG, MB, GM, MN
12	18	72	78	1	1-wide	1	U1288-1	U1288-1A	PT, HG, MB, GM, MN
12	18	72	78	1	3-wide	3	U3288-1	U3288-1A	PT, HG, MB, GM, MN
15	15	72	78	1	1-wide	1	U1558-1	U1558-1A	PT, HG
15	15	72	78	1	3-wide	3	U3558-1	U3558-1A	PT, HG
15	18	72	78	1	1-wide	1	U1588-1	U1588-1A	PT, HG
15	18	72	78	1	3-wide	3	U3588-1	U3588-1A	PT, HG
15	21	72	78	1	1-wide	1	U1518-1	U1518-1A	PT
15	21	72	78	1	3-wide	3	U3518-1	U3518-1A	PT
15	24	72	78	1	1-wide	1	U1548-1	U1548-1A	PT
15	24	72	78	1	3-wide	3	U3548-1	U3548-1A	PT
18	18	72	78	1	1-wide	1	U1888-1	U1888-1A	PT, HG
18	18	72	78	1	3-wide	3	U3888-1	U3888-1A	PT, HG
18	21	72	78	1	1-wide	1	U1818-1	U1818-1A	PT, HG
18	21	72	78	1	3-wide	3	U3818-1	U3818-1A	PT, HG
18	24	72	78	1	1-wide	1	U1848-1	U1848-1A	PT
18	24	72	78	1	3-wide	3	U3848-1	U3848-1A	PT
DOUBLE TIER									
12	12	30	66	2	1-wide	2	U1226-2	U1226-2A	PT, HG
12	12	30	66	2	3-wide	6	U3226-2	U3226-2A	PT, HG
12	15	30	66	2	1-wide	2	U1256-2	U1256-2A	PT, HG
12	15	30	66	2	3-wide	6	U3256-2	U3256-2A	PT, HG
12	18	30	66	2	1-wide	2	U1286-2	U1286-2A	PT, HG
12	18	30	66	2	3-wide	6	U3286-2	U3286-2A	PT, HG
12	12	36	78	2	1-wide	2	U1228-2	U1228-2A	PT, HG, MB, GM, MN
12	12	36	78	2	3-wide	6	U3228-2	U3228-2A	PT, HG, MB, GM, MN
12	15	36	78	2	1-wide	2	U1258-2	U1258-2A	PT, HG, MB, GM, MN
12	15	36	78	2	3-wide	6	U3258-2	U3258-2A	PT, HG, MB, GM, MN
12	18	36	78	2	1-wide	2	U1288-2	U1288-2A	PT, HG, MB, GM, MN
12	18	36	78	2	3-wide	6	U3288-2	U3288-2A	PT, HG, MB, GM, MN
15	15	36	78	2	1-wide	2	U1558-2	U1558-2A	PT, HG
15	15	36	78	2	3-wide	6	U3558-2	U3558-2A	PT, HG
15	18	36	78	2	1-wide	2	U1588-2	U1588-2A	PT, HG
15	18	36	78	2	3-wide	6	U3588-2	U3588-2A	PT, HG
15	21	36	78	2	1-wide	2	U1518-2	U1518-2A	PT
15	21	36	78	2	3-wide	6	U3518-2	U3518-2A	PT
15	24	36	78	2	1-wide	2	U1548-2	U1548-2A	PT
15	24	36	78	2	3-wide	6	U3548-2	U3548-2A	PT
TRIPLE TIER									
12	12	24	78	3	1-wide	3	U1228-3	U1228-3A	PT, HG, MB, GM, MN
12	12	24	78	3	3-wide	9	U3228-3	U3228-3A	PT, HG, MB, GM, MN
12	15	24	78	3	1-wide	3	U1258-3	U1258-3A	PT, HG, MB, GM, MN
12	15	24	78	3	3-wide	9	U3258-3	U3258-3A	PT, HG, MB, GM, MN
12	18	24	78	3	1-wide	3	U1288-3	U1288-3A	PT, HG, MB, GM, MN
12	18	24	78	3	3-wide	9	U3288-3	U3288-3A	PT, HG, MB, GM, MN



Triple Tier, 3 wide, 9 openings



Triple Tier, 3 wide, 9 openings



Double Tier, 3 wide, 6 openings



Triple Tier, 3 wide, 9 openings

COLOR SELECTION

Note: Parchment, Hallowell Gray and Marine Blue lockers include matching body colors. Maroon and Green Mist lockers include Parchment body and sides. Some sizes and models are available in limited colors. For current color availability visit: www.Hallowell-List.com.

729
PARCHMENT (PT)

725
HALLOWELL GRAY (HG)

707
MARINE BLUE (MB)

705
GREEN MIST (GM)
PARCHMENT BODY

727
MAROON (MN)
PARCHMENT BODY

5 DAY SHIPPING ON ALL IN-STOCK PRODUCTS

STOCK PROGRAM

Quick Ship



**PREMIUM BOX
KD STOCK LOCKERS**

THE FASTEST SHIPPING IN THE INDUSTRY...



Five Tier,
1 wide,
5 openings

Five Tier,
1 wide,
5 openings

Six Tier,
1 wide,
6 openings

Six Tier,
1 wide,
6 openings

Six Tier,
1 wide,
6 openings

Six Tier,
1 wide,
6 openings

Six Tier,
1 wide,
6 openings

**With Piano
Hinge**



Six Tier,
3 wide,
18 openings



Single-point thru-the-door friction catch door pull designed for use with a padlock or built-in lock. Shown with optional strike plate which protects door from being marred by padlock and standard piano hinge.



Sixteen-Person
Lockers



4-Wide Wall Mount Lockers

**RESISTANT
RESISTANT**
GALVANITE
SHEET STEEL
can be ordered
ON ANY PRODUCTION
LOCKER OR CABINET
AS AN OPTION

When you order the Galvanite Option, Lockers are fabricated from prime galvanized (hot-dipped zinc coated, annealed) sheet steel, then finished with an electrostatically applied high grade powder coat finish providing double protection against corrosion.

PREMIUM BOX KD STOCK LOCKERS

Hallowell
www.Hallowell-List.com

PREMIUM KD STOCK BOX LOCKERS

Hallowell Premium box lockers include louvered doors and are perfect for storing personal items.

FEATURES:

BODY CONSTRUCTION: Knock-down, 24 gauge
BODY STYLES: Four, five, six tier, 16 Person and wall mount
DOOR: 18 gauge, Louvered for added ventilation
HINGES: Continuous piano type
HANDLE: Single-point projecting friction catch door pull prepared for both padlock or built-in lock. No moving parts insures quiet maintenance-free operation.
HOOKS: None
COAT RODS: None, standard on the 16 person
SHELVES: None
LEGS: 6" high legs are standard. Lockers without legs are available for a nominal charge.
APPEARANCE: Parchment, Hallowell Gray and Marine Blue lockers include matching body colors. Maroon and Green Mist lockers include Parchment body and sides. Order Finished End Panels for exposed row ends if desired. Finished End Panels install over top of universal side panels adding strength and rigidity at exposed row ends and can be ordered to match locker door/frame color.

GENERAL FEATURES:

- Lockers can be ordered fully-assembled or knock-down for assembly at destination.
- Order 3-wide units for best value. Order 1-wide units to complete quantity needed for each continuous row.
- Lockers can be ordered in combination with Premium wardrobe lockers.
- All items shown are available for shipment within 5 business days of receipt of order.
- Aluminum number plates (#1-up) with mounting hardware are included. Number plate face is black with silver etched numerals. If a special numbering sequence is required, please specify when ordering. Number sequence must be consecutive numbers equal to the number of openings (doors) ordered.
- Locks are not included.



Width	Depth	Opening Height	Frame Height	Tier	Grouping	Openings Per Group	Knock-Down Cat No.	Fully-Assembled Cat No.	Color Selection
FIVE TIER									
12	12	12	66	5	1-wide	5	U1226-5	U1226-5A	PT, HG
12	12	12	66	5	3-wide	15	U3226-5	U3226-5A	PT, HG
12	15	12	66	5	1-wide	5	U1256-5	U1256-5A	PT, HG
12	15	12	66	5	3-wide	15	U3256-5	U3256-5A	PT, HG
12	18	12	66	5	1-wide	5	U1286-5	U1286-5A	PT, HG
12	18	12	66	5	3-wide	15	U3286-5	U3286-5A	PT, HG
SIX TIER									
12	12	12	78	6	1-wide	6	U1228-6	U1228-6A	PT, HG, MB, GM, MN
12	12	12	78	6	3-wide	18	U3228-6	U3228-6A	PT, HG, MB, GM, MN
12	15	12	78	6	1-wide	6	U1258-6	U1258-6A	PT, HG, MB, GM, MN
12	15	12	78	6	3-wide	18	U3258-6	U3258-6A	PT, HG, MB, GM, MN
12	18	12	78	6	1-wide	6	U1288-6	U1288-6A	PT, HG, MB, GM, MN
12	18	12	78	6	3-wide	18	U3288-6	U3288-6A	PT, HG, MB, GM, MN
4-WIDE WALL MOUNT									
48	18	12	14-3/4	4-Wide Wall Mount		4	U1482-4WM	U1482-4WM-A	PT, HG
72	18	12	78	16-Person Unit		16	U1788-16	U1788-16A	PT, HG

COLOR SELECTION

Note: Parchment, Hallowell Gray and Marine Blue lockers include matching body colors. Maroon and Green Mist lockers include Parchment body and sides. Some sizes and models are available in limited colors. For current color availability visit: www.Hallowell-List.com.

729
PARCHMENT (PT)

725
HALLOWELL GRAY (HG)

707
MARINE BLUE (MB)

705
GREEN MIST (GM)
PARCHMENT BODY

727
MAROON (MN)
PARCHMENT BODY

5 DAY SHIPPING ON ALL IN-STOCK PRODUCTS

STOCK → PROGRAM

Quick Ship



**SPECIALLY FORMULATED
ANTIMICROBIAL FINISH**

THE FASTEST SHIPPING IN THE INDUSTRY...

MedSafe™

Antimicrobial Health care Lockers

Specially formulated powder coat finish protects against bacteria, mold, yeast & mildew for up to 20 years!



With Piano Hinge

HAT SHELF,
COAT HOOKS
AND 6" LEGS
ARE STANDARD

Double Tier,
1 wide,
2 openings

Single Tier,
1 wide,
1 opening

FEATURES:

- BODY CONSTRUCTION:** Knock-down, 24 gauge
- BODY STYLES:** Single and double tier
- CUSTOM FEATURES:** Antimicrobial finish
- DOOR:** 16 gauge, louvered for added ventilation,
- HINGES:** Continuous piano type
- HANDLE:** Stainless steel recessed handle with multi-point gravity lift-type latching. Recessed handle protects finish from being marred by padlock.
- HOOKS:** One double prong ceiling hook and two single hooks per single and double tier opening.
- COAT RODS:** Available for single tier at a nominal cost
- SHELVES:** Hat shelf is included in single tier lockers.
- LEGS:** All stock lockers are standard with 6" high legs. Lockers without legs are available for a nominal charge.



Width	Depth	Opg Hgt	Frm Hgt	Tier	Grouping	Openings Per Group	Knock-Down Cat No.	Fully-Assembled Cat No.	Color Selection
SINGLE TIER									
12	18	72	78	1	1-wide	1	UMS1288-1	UMS1288-1A	PL
12	18	72	78	1	3-wide	3	UMS3288-1	UMS3288-1A	PL
15	18	72	78	1	1-wide	1	UMS1588-1	UMS1588-1A	PL
15	18	72	78	1	3-wide	3	UMS3588-1	UMS3588-1A	PL
18	18	72	78	1	1-wide	1	UMS1888-1	UMS1888-1A	PL
18	18	72	78	1	3-wide	3	UMS3888-1	UMS3888-1A	PL
DOUBLE TIER									
12	18	36	78	2	1-wide	2	UMS1288-2	UMS1288-2A	PL
12	18	36	78	2	3-wide	6	UMS3288-2	UMS3288-2A	PL
15	18	36	78	2	1-wide	2	UMS1588-2	UMS1588-2A	PL
15	18	36	78	2	3-wide	6	UMS3588-2	UMS3588-2A	PL



**HALLOWELL QUALITY
TO FIT A SMALL BUDGET**



Hallowell
www.Hallowell-List.com

VALUEMAX™ ECONOMY LOCKERS

ValueMax™ economy lockers

ValueMax lockers offer exceptional value, quality and finish at an affordable price.

FEATURES:

- BODY CONSTRUCTION:** Knock-down, 24 gauge
- BODY STYLES:** Single, double and triple tier
- DOOR:** 16 gauge, louvered for added ventilation
- HINGES:** Continuous piano type
- HANDLE:** Single-point thru-the-door friction catch door pull designed for use with a padlock
- HOOKS:** One double prong ceiling hook and two single hooks per single and double tier opening. One double ceiling hook for triple tier.
- COAT RODS:** Available for single tier at a nominal cost
- SHELVES:** Hat shelf is included in single tier lockers.
- LEGS:** 6" high legs are standard. Lockers without legs are available for a nominal charge.



ValueMax lockers are the perfect solution for limited budget projects.

Width	Depth	Opening Height	Frame Height	Tier	Grouping	Openings Per Group	Knock-Down Cat No.	Fully-Assembled Cat No.	Color Selection
SINGLE TIER									
12	12	72	78	1	1-wide	1	UH1228-1	UH1228-1A	PT, HG
12	12	72	78	1	3-wide	3	UH3228-1	UH3228-1A	PT, HG
12	15	72	78	1	1-wide	1	UH1258-1	UH1258-1A	PT, HG
12	15	72	78	1	3-wide	3	UH3258-1	UH3258-1A	PT, HG
12	18	72	78	1	1-wide	1	UH1288-1	UH1288-1A	PT, HG
12	18	72	78	1	3-wide	3	UH3288-1	UH3288-1A	PT, HG
DOUBLE TIER									
12	12	36	78	2	1-wide	2	UH1228-2	UH1228-2A	PT, HG
12	12	36	78	2	3-wide	6	UH3228-2	UH3228-2A	PT, HG
12	15	36	78	2	1-wide	2	UH1258-2	UH1258-2A	PT, HG
12	15	36	78	2	3-wide	6	UH3258-2	UH3258-2A	PT, HG
12	18	36	78	2	1-wide	2	UH1288-2	UH1288-2A	PT, HG
12	18	36	78	2	3-wide	6	UH3288-2	UH3288-2A	PT, HG
TRIPLE TIER									
12	12	24	78	3	1-wide	3	UH1228-3	UH1228-3A	PT, HG
12	12	24	78	3	3-wide	9	UH3228-3	UH3228-3A	PT, HG
12	15	24	78	3	1-wide	3	UH1258-3	UH1258-3A	PT, HG
12	15	24	78	3	3-wide	9	UH3258-3	UH3258-3A	PT, HG
12	18	24	78	3	1-wide	3	UH1288-3	UH1288-3A	PT, HG
12	18	24	78	3	3-wide	9	UH3288-3	UH3288-3A	PT, HG



COLOR SELECTION

729 PARCHMENT (PT)

725 Hallowell Gray (HG)

5 DAY SHIPPING ON ALL IN-STOCK PRODUCTS

STOCK → PROGRAM

Quick Ship

THE FASTEST SHIPPING IN THE INDUSTRY...



WHEN MONITORING OF LOCKER CONTENTS IS REQUIRED

KD Wardrobe Lockers

SAFETY VIEW®



Double Tier,
3 wide,
6 openings

WARDROBE LOCKER FEATURES:

BODY CONSTRUCTION: Knock-down, 24 gauge

BODY STYLES: Single, double and triple tier

DOOR: 16 gauge steel with two high strength injection molded polycarbonate panels per door for easy content viewing

HINGES: Continuous piano type

HANDLE: Stainless steel recessed handle with multi-point gravity lift-type latching. Recessed handle protects finish from being marred by padlock.

HOOKS: One double prong ceiling hook and two single hooks per single and double tier opening. One double ceiling hook for triple tier

COAT RODS: Available for single tier at a nominal cost

SHELVES: Hat shelf is included in single tier lockers

LEGS: 6" high legs are standard. Lockers without legs are available for a nominal charge.

NOTES: Meets UL flammability standards, Polycarbonate is approved by the Consumer Product Safety Commission (CPSC16CFR 1201)

With Piano
Hinge

Width	Depth	Opening Height	Frame Height	Tier	Grouping	Opening Per Group	Knock-Down Cat No.	Fully-Assembled Cat No.	Color Selection
SINGLE TIER									
12	12	72	78	1	1-wide	1	USV1228-1	USV1228-1A	PT
12	12	72	78	1	3-wide	3	USV3228-1	USV3228-1A	PT
12	15	72	78	1	1-wide	1	USV1258-1	USV1258-1A	PT
12	15	72	78	1	3-wide	3	USV3258-1	USV3258-1A	PT
12	18	72	78	1	1-wide	1	USV1288-1	USV1288-1A	PT
12	18	72	78	1	3-wide	3	USV3288-1	USV3288-1A	PT
DOUBLE TIER									
12	12	36	78	2	1-wide	2	USV1228-2	USV1228-2A	PT
12	12	36	78	2	3-wide	6	USV3228-2	USV3228-2A	PT
12	15	36	78	2	1-wide	2	USV1258-2	USV1258-2A	PT
12	15	36	78	2	3-wide	6	USV3258-2	USV3258-2A	PT
12	18	36	78	2	1-wide	2	USV1288-2	USV1288-2A	PT
12	18	36	78	2	3-wide	6	USV3288-2	USV3288-2A	PT
TRIPLE TIER									
12	12	24	78	3	1-wide	3	USV1228-3	USV1228-3A	PT
12	12	24	78	3	3-wide	9	USV3228-3	USV3228-3A	PT
12	15	24	78	3	1-wide	3	USV1258-3	USV1258-3A	PT
12	15	24	78	3	3-wide	9	USV3258-3	USV3258-3A	PT
12	18	24	78	3	1-wide	3	USV1288-3	USV1288-3A	PT
12	18	24	78	3	3-wide	9	USV3288-3	USV3288-3A	PT

COLOR
SELECTION

729
PARCHMENT (PT)

**SEE WHAT YOU
ARE MISSING**



Hallowell
www.Hallowell-List.com

SAFETY-VIEW® AND SAFETY-VIEW® PLUS

**SAFETY
VIEW®
PLUS**

KD Box Lockers

BOX LOCKER FEATURES:

BODY CONSTRUCTION: Knock-down, 24 gauge
BODY STYLES: Six tier, Sixteen Person and wall mount
DOOR: High strength injection molded clear polycarbonate doors for unobstructed content viewing
HINGES: Continuous piano type
HANDLE: Single-point projecting friction catch door pull prepared for both padlock or built-in lock
HOOKS: None
COAT RODS: Standard on Sixteen person
SHELVES: None
LEGS: 6" high legs are standard. Lockers without legs are available for a nominal charge
NOTES: Meets UL flammability standards, Polycarbonate is approved by the Consumer Product Safety Commission (CPSC16CFR 1201) U.S. Patent No. D458 064S

GENERAL FEATURES:

- Aluminum number plates (#1-up) with mounting hardware are included.
- Locks are not included.
- Safety-View plus doors provide an unobstructed view of locker contents
- Can be ordered fully-assembled or knock-down for assembly at destination
- Order 3-wide units for best value. Order 1-wide units to complete quantity needed for each continuous row
- Available for immediate



Six Tier, 3 wide, 18 openings



**ADA
Compliant
Lockers**



4 Wide wall mount

Sixteen person shown with optional closed base



Unobstructed view of locker contents

Width	Depth	Opening Height	Frame Height	Tier	Grouping	Opening Per Group	Knock-Down Cat No.	Fully-Assembled Cat No.	Color Selection
SIX TIERS									
12	12	12	78	6	1-wide	6	USVP1228-6	USVP1228-6A	PT
12	12	12	78	6	3-wide	18	USVP3228-6	USVP3228-6A	PT
12	15	12	78	6	1-wide	6	USVP1258-6	USVP1258-6A	PT
12	15	12	78	6	3-wide	18	USVP3258-6	USVP3258-6A	PT
12	18	12	78	6	1-wide	6	USVP1288-6	USVP1288-6A	PT
12	18	12	78	6	3-wide	18	USVP3288-6	USVP3288-6A	PT
4-WIDE WALL MOUNT									
48	18	12	14-3/4	4-Wide Wall Mount		4	USVP1482-4WM	USVP1482-4WMA	PT
16-PERSON UNIT									
72	18	12	78	16-Person Unit		16	USVP1788-16	USVP1788-16A	PT
ADA UNIT									
12	12	12/36	78	ADA	1-wide	4	USVP1228ADA	USVP1228ADA-A	PT
12	12	12/36	78	ADA	3-wide	12	USVP3228ADA	USVP3228ADA-A	PT
12	15	12/36	78	ADA	1-wide	4	USVP1258ADA	USVP1258ADA-A	PT
12	15	12/36	78	ADA	3-wide	12	USVP3258ADA	USVP3258ADA-A	PT
12	18	12/36	78	ADA	1-wide	4	USVP1288ADA	USVP1288ADA-A	PT
12	18	12/36	78	ADA	3-wide	12	USVP3288ADA	USVP3288ADA-A	PT

COLOR SELECTION

729 PARCHMENT (PT)

5 DAY SHIPPING ON ALL IN-STOCK PRODUCTS

STOCK → PROGRAM

Quick Ship

THE RICH LOOK AND DURABILITY OF STAINLESS STEEL

THE FASTEST SHIPPING IN THE INDUSTRY...

304 STAINLESS STEEL



Hallowell 304 Stainless steel lockers are the perfect locker solution for areas prone to rust and sanitation concerns and are ideal for food industry, pool area and outdoor applications.

STAINLESS STEEL LOCKERS



Single Tier, 1 wide, 1 opening

Double Tier, 3 wide, 6 openings

Six Tier, 1 wide, 6 openings

FEATURES:

BODY CONSTRUCTION: Knock-down, 24 gauge

BODY STYLES: Single, double and six tier

DOOR: 16 gauge, louvered for added ventilation

HINGES: 2-1/2" 5-knuckle hinges. Three hinges per single tier door and two hinges per double or six tier door.

HANDLE: Single and double tier locker have a deep drawn stainless steel handle with multi-point gravity lift-type latching. Six tier lockers have a single-point projecting friction catch door pull.

HOOKS: One double prong ceiling hook and two single hooks per single and double tier opening. No hooks for six tier.

COAT RODS: Available for single tier at a nominal cost

SHELVES: Hat shelf is included in single tier lockers.

LEGS: 6" high legs are standard. Lockers without legs are available for a nominal charge.



Width	Depth	Opening Height	Frame Height	Tier	Grouping	Openings Per Group	Knock-Down Cat No.	Fully-Assembled Cat No.
SINGLE TIER								
12	18	72	78	1	1-wide	1	USS1288-1	USS1288-1A
12	18	72	78	1	3-wide	3	USS3288-1	USS3288-1A
18	18	72	78	1	1-wide	1	USS1888-1	USS1888-1A
18	18	72	78	1	3-wide	3	USS3888-1	USS3888-1A
DOUBLE TIER								
12	18	36	78	2	1-wide	2	USS1288-2	USS1288-2A
12	18	36	78	2	3-wide	6	USS3288-2	USS3288-2A
18	18	36	78	2	1-wide	2	USS1888-2	USS1888-2A
18	18	36	78	2	3-wide	6	USS3888-2	USS3888-2A
SIX TIER								
12	18	12	78	6	1-wide	6	USS1288-6	USS1288-6A
12	18	12	78	6	3-wide	18	USS3288-6	USS3288-6A
18	18	12	78	6	1-wide	6	USS1888-6	USS1888-6A
18	18	12	78	6	3-wide	18	USS3888-6	USS3888-6A

**ALL-WELDED
HEAVY-DUTY
CORROSION RESISTANT**



Hallowell
www.Hallowell-List.com

BENCHES, PEDESTALS AND LOCKS

MAXVIEW™

All-Welded Lockers

Hallowell All-Welded MaxView lockers are perfect for tool, equipment and gear storage.

FEATURES:

BODY CONSTRUCTION: All-welded 16 gauge heavy-duty tubular frame construction from galvanized sheet steel, sides and back are 1/2" 13 gauge flattened expanded metal. Top and bottom are heavy-duty galvanized corrosion resistant sheet steel, fully-assembled

BODY STYLES: Single tier

DOOR: 14 gauge door is diamond perforated for maximum visibility and ventilation.

Includes a welded-in full height door stiffener
HINGES: Heavy-duty 13 gauge 7-knuckle (3 hinges per door)

HANDLE Single-point projecting friction catch door pull prepared for both padlock or built-in lock.

SHELVES: Four 16 gauge sheet steel welded-in fixed shelves are fabricated from galvanized corrosion resistant sheet steel add additional rigidity to the unit.



- ✓ All-welded heavy-duty construction
- ✓ 4 sided viewing of locker contents
- ✓ 4 sided ventilation
- ✓ Corrosion resistant
- ✓ Lifetime warranty
- ✓ Full height 3-1/2" wide door stiffener

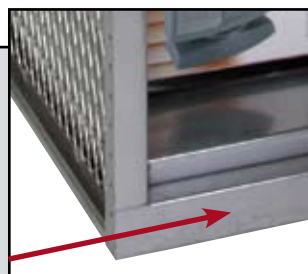

Heavy gauge tubular frame. Bottom shelf of locker sits a full 2-3/4" above finished floor protecting locker contents from water damage.



Width	Depth	Opening Height	Frame Height	Tier	Grouping	Openings Per Group	Fully-Assembled Cat No.	Color Selection
ONE TIER								
18-3/4	18	72	74-3/4	1	1-wide	1	HLV882-1SS	SS



5 DAY SHIPPING ON ALL IN-STOCK PRODUCTS

THE FASTEST SHIPPING IN THE INDUSTRY...

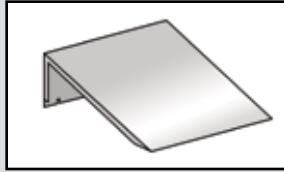

INDIVIDUAL SLOPE TOPS

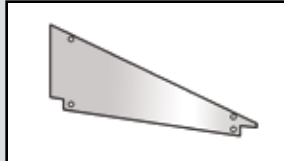

END CLOSURES FOR INDIVIDUAL SLOPE TOPS

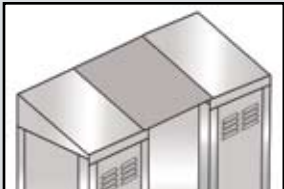

SLOPE TOP FILLER

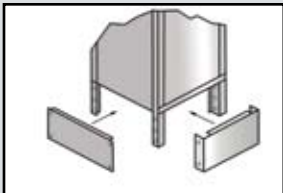

CLOSED FRONT AND SIDE BASE

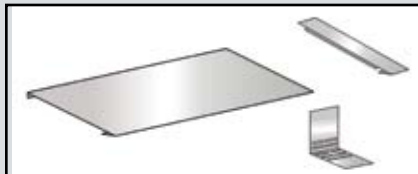

CONTINUOUS SLOPE TOP

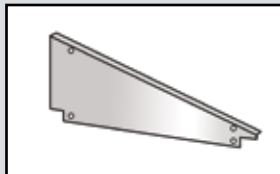

END CLOSURES FOR CONTINUOUS SLOPE TOPS

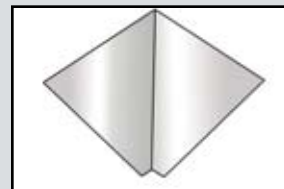

SLOPE TOP CORNER

Width	Depth	Height	Cat. No.	Color Selection
INDIVIDUAL SLOPE TOPS				
12	12	4	KISTT1212	PT, HG, MB, GM, MN
12	15	5	KISTT1215	PT, HG, MB, GM, MN
12	18	6	KISTT1218	PT, HG, MB, GM, MN
15	15	5	KISTT1515	PT, HG
15	18	6	KISTT1518	PT, HG
15	21	7	KISTT1521	PT
18	18	6	KISTT1818	PT, HG
18	21	7	KISTT1821	PT, HG
18	24	8	KISTT1824	PT
END CLOSURES (FOR INDIVIDUAL SLOPE TOPS)				
	12	4	KISE12	PT, HG, MB, GM, MN
	15	5	KISE15	PT, HG, MB, GM, MN
	18	6	KISE18	PT, HG, MB, GM, MN
	21	7	KISE21	PT, HG
	24	8	KISE24	PT
SLOPE TOP FILLER (FOR INDIVIDUAL SLOPE TOPS)				
6	12	4	KSTF0612	PT, HG, MB, GM, MN
6	15	5	KSTF0615	PT, HG, MB, GM, MN
6	18	6	KSTF0618	PT, HG, MB, GM, MN
12	12	4	KSTF1212	PT, HG, MB, GM, MN
12	15	5	KSTF1215	PT, HG, MB, GM, MN
12	18	6	KSTF1218	PT, HG, MB, GM, MN
CONTINUOUS SLOPE TOP				
72	12	4	CST1272	PT, HG, MB, GM, MN
72	15	5	CST1572	PT, HG, MB, GM, MN
72	18	6	CST1872	PT, HG, MB, GM, MN
END CLOSURES (FOR CONTINUOUS SLOPE TOP)				
	12	4	WCSE12	PT, HG, MB, GM, MN
	15	5	WCSE15	PT, HG, MB, GM, MN
	18	6	WCSE18	PT, HG, MB, GM, MN
SLOPE TOP CORNER				
	12	12	STC12	PT, HG, MB, GM, MN
	15	15	STC15	PT, HG, MB, GM, MN
	18	18	STC18	PT, HG, MB, GM, MN
CLOSED FRONT BASE				
12		6	KCFB12	PT, HG, MB, GM, MN
15		6	KCFB15	PT, HG
18		6	KCFB18	PT, HG
CLOSED SIDE BASE				
12		6	KCSB12	PT, HG, MB, GM, MN
15		6	KCSB15	PT, HG, MB, GM, MN
18		6	KCSB18	PT, HG, MB, GM, MN
21		6	KCSB21	PT, HG
24		6	KCSB24	PT

COMPLETE SELECTION OF LOCKER ACCESSORIES

Hallowell®

www.Hallowell-List.com

LOCKER ACCESSORIES

Width	Depth	Height	Cat. No.	Color Selection
Z-BASE FRONTS				
72		4	KZBF-N	PT, HG, MB, GM, MN
Z-BASE ENDS				
	12	4	KZBE12-N	PT, HG, MB, GM, MN
	15	4	KZBE15-N	PT, HG, MB, GM, MN
	18	4	KZBE18-N	PT, HG, MB, GM, MN
Z-BASE SPLICE				
3			KZBS-N	PT
TOP RECESSED TRIM				
72		3	KRT-T	PT, HG, MB, GM, MN
TOP RECESSED TRIM SPLICE				
3		3	KRT-SC	PT, HG, MB, GM, MN
SIDE RECESS TRIM				
3		63	KRT60L	PT
3		63	KRT60R	PT
3		75	KRT72L	PT, HG, MB, GM, MN
3		75	KRT72R	PT, HG, MB, GM, MN
COAT RODS				
12			KCR12	Plated
15			KCR15	Plated
18			KCR18	Plated
21			KCR21	Plated
24			KCR24	Plated
7.5 (For Duplex and Two-Person only)			KCR15L	Plated
7.5 (For Duplex and Two-Person only)			KCR15R	Plated
FRONT FILLERS				
6		66	KFSF0666	PT
12		66	KFSF1266	PT
6		78	KFSF0678	PT, HG, MB, GM, MN
12		78	KFSF1278	PT, HG, MB, GM, MN
FILLER SLIP JOINTS				
		66	KG66	PT
		78	KG78	PT, HG, MB, GM, MN
UNIVERSAL ANGLE				
1	2	72	AF010272	PT
FLAT TOP FILLERS				
6	12		KFTF0612	PT, HG, MB, GM, MN
6	15		KFTF0615	PT, HG, MB, GM, MN
6	18		KFTF0618	PT, HG, MB, GM, MN
12	12		KFTF1212	PT, HG, MB, GM, MN
12	15		KFTF1215	PT, HG, MB, GM, MN
12	18		KFTF1218	PT, HG, MB, GM, MN
FLAT TOP CORNER				
12	12		FTC12	PT, HG, MB, GM, MN
15	15		FTC15	PT, HG, MB, GM, MN
18	18		FTC18	PT, HG, MB, GM, MN
UNIVERSAL END PANELS				
	12	60	KMP1260	PT, HG
	15	60	KMP1560	PT, HG
	18	60	KMP1860	PT, HG
	12	72	KMP1272	PT, HG, MB, GM, MN
	15	72	KMP1572	PT, HG, MB, GM, MN
	18	72	KMP1872	PT, HG, MB, GM, MN
	21	72	KMP2172	PT, HG
	24	72	KMP2472	PT

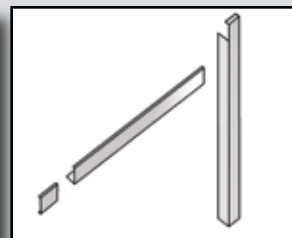

RECESSED TRIM

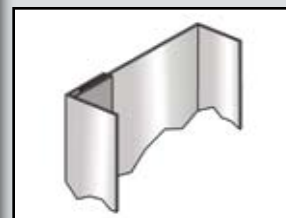

FRONT FILLER AND SLIP JOINT

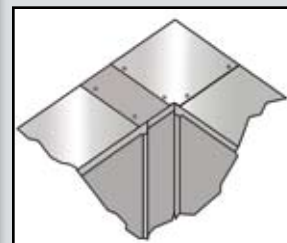

FLAT TOP FILLER

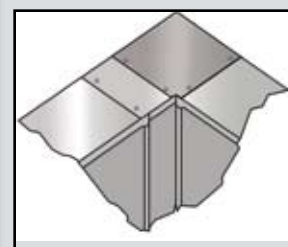

FLAT TOP CORNER



COAT RODS

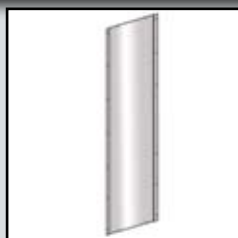

UNIVERSAL END PANEL

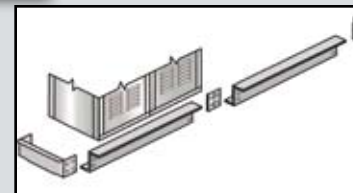

Z-BASE FRONTS, ENDS, SPLICE

5 DAY SHIPPING ON ALL IN-STOCK ACCESSORIES

U-BOAT UTILITY CART

U-Boat stocking carts are designed to replenish finished products in high traffic areas such as a retail location. Heavy-duty and durable steel construction makes it easy to handle the heaviest of loads. The 16" wide X 60" long cart turns on the two fixed 8" center casters allowing it to rotate on its central axis. The four 4" swivel end casters help make turning easy. Each handle is engineered to be comfortable and useful; the cross members act as reinforcements and as supports for an optional shelf. The non-slip diamond plated main deck helps keep loads from shifting during use.



Width	Length	Capacity	Catalog No.	Color
16	60	2,000 lbs	PUB6016BL	Blue

BENCHES, PEDESTALS AND LOCKS

Hallowell®

www.Hallowell-List.com

BENCHES, PEDESTALS AND LOCKS



4805 Steel Pedestal
Fabricated from 10 gauge sheet steel with flanges welded to upright tube. Color: Parchment



4825 Stainless Steel Moveable Pedestal
Fabricated from 16 gauge stainless steel. Includes holes for permanent anchoring to floor. Color: Unpainted



8032 Adjustable Steel Pedestal
With cast aluminum base and concealed anchoring to floor. Color: Parchment



4810 Heavy-Duty Cast Iron Pedestal
With 6" diameter top and bottom. Provided with three anchoring holes at top and bottom. Color: Parchment



4820 Aluminum Moveable Pedestal
Includes holes for optional permanent anchoring to floor. Color: Parchment

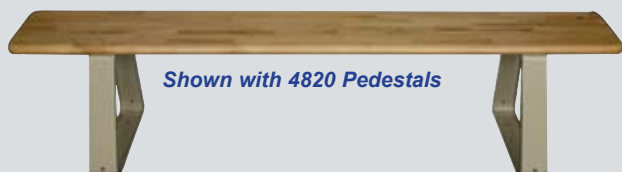

Shown with 4820 Pedestals

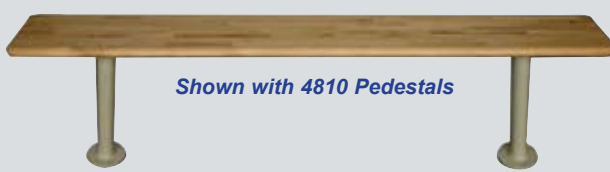

Shown with 4810 Pedestals

Benchtop Length	3' - 8'	9' - 14'	15'
Pedestals Required	2	3	4

Note: Benchtop lengths over 15' will be supplied in sections

Locker Benches are 9-1/2" wide x 1-1/4" thick and made from laminated hardwood. They are finished with one coat deep penetrating hot sealer and two coats of heavy body high impact hot hydraulically applied lacquer. Bench tops are standard in one foot increments from 3' thru 15'. Non-standard lengths are available on special order (pedestal requirement will be for next standard size up).

Non-Stock Quick Ship Items - Call for Availability and Lead times.



SAFE-O-MAT® Built-In Coin, Token and Card Locks
Available in coin return and coin collect as well as token collect and card access styles



Digilock® KT and KP Series
Digital locks allow access using a programmable four-digit code



Digilock® T-Series
Digitally controlled locks allow access by touching a key fob to the lock which automatically unlocks the door.



Hallowell Digital Locks
Digital locks allow access using a programmable four-digit code

NOTE: An ADA compliant lock must be used on any locker that is required to meet ADA guidelines

Padlocks, Built-in Locks and Specialty Locks

Hallowell recommends ZEPHYR® locks for use on all of our Lockers.



Zephyr® Built-In Combination Locks
Available in spring-bolt and dead-bolt styles, are key controlled and include multiple combination settings



Zephyr® Combination Padlocks
Available standard and master-keyed, padlocks can be used on all locker types



Zephyr® Built-In Key Locks
Available in spring-bolt and dead-bolt styles and available standard or master-keyed



Zephyr® 1730
ADA compliant for use on gravity lift-type latches

5 DAY SHIPPING ON ALL IN-STOCK PRODUCTS



2823 W. Orange Ave. Apopka, FL 32703

866-566-0500

Tel: 407-464-3611

Fax: 407-464-3610

www.Hallowell-List.com

